

# FASTTRAK

Simple, Strong,  
Quick & Easy.

## ASSEMBLY INSTRUCTIONS

# G68



### NOTES

BEFORE COMMENCING SHED ASSEMBLY, CHECK ALL PARTS. IF THERE IS A DISCREPANCY, PLEASE CALL YARDSAVER (SEE REAR OF INSTRUCTION BOOK)

#### DO NOT ASSEMBLE IN WINDY CONDITIONS



#### READ INSTRUCTIONS FIRST



#### 2 PERSON ASSEMBLY



THE MANUFACTURERS CANNOT BE HELD RESPONSIBLE FOR ANY CONSEQUENCES DUE TO SHEDS THAT ARE NOT INSTALLED PER INSTRUCTIONS OR FOR DAMAGE DUE TO WEATHER CONDITIONS, ACTS OF GOD OR FOR SHEDS THAT ARE LEFT PARTIALLY ASSEMBLED OVERNIGHT. PARTS MAY CONTAIN SHARP EDGES & CORNERS. CARE MUST BE TAKEN WHEN HANDLING VARIOUS PIECES TO AVOID A MISHAP, FOR SAFETY SAKE, PLEASE USE A PAIR OF WORK GLOVES, EYE PROTECTION & PROTECTIVE CLOTHING WHEN ASSEMBLING OR PERFORMING ANY MAINTENANCE ON THE BUILDING.

## TOOLS REQUIRED



Electric Drill



Cordless Drill



Measuring Tape



Screwdrivers



8mm Masonry Drill Bit



Shifting Spanner



Builders Pencil



Tin Snips  
(some models only)



Rubber Mallet



Sturdy Ladder  
(two if possible)



Gloves



Protective Eyewear

## HANDY HINTS FOR CONSTRUCTION



Read instructions and check parts carefully before assembling the shed.



Please wear safety gloves and glasses at all times to protect against sharp metal edges.



Do not assemble in windy conditions as panels may be difficult to handle and damage may result.











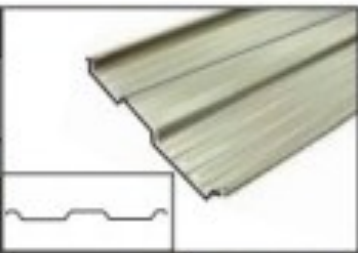

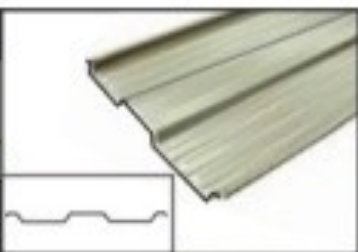

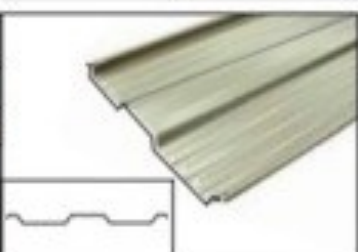

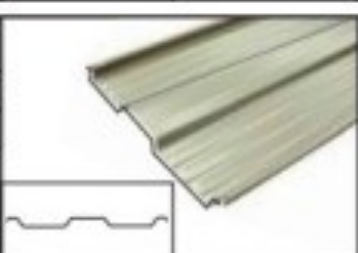
Do not back fill against the shed as this will result in corrosion. Allow drainage from the site.

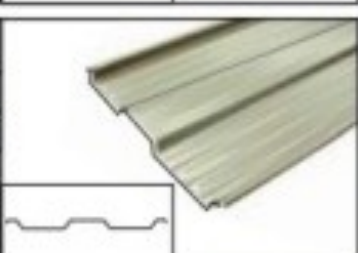

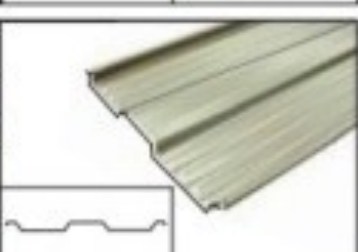

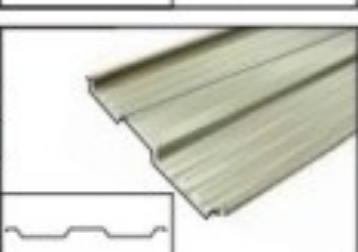









**MOST PILOT HOLES ARE PRE-PUNCHED AND IN THIS CASE DRILLING HOLES IS NOT NECESSARY, HOWEVER SOME PILOT HOLES NEED TO BE DRILLED WITH THE INCLUDED 2.5MM DRILL BIT WHERE INDICATED**

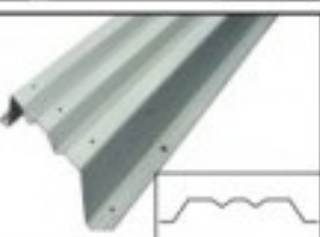



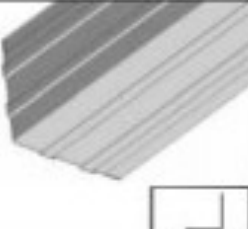



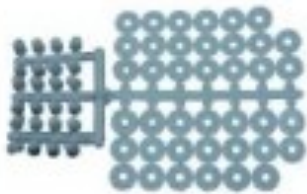

# PARTS LIST

<table border="1"> <tr> <th colspan="3">PRODUCT NUMBERS</th> </tr> <tr> <td>A1</td> <td>A2</td> <td>A3</td> </tr> <tr> <td>A4</td> <td>A5</td> <td>A6</td> </tr> <tr> <td>A7</td> <td>A8</td> <td></td> </tr> <tr> <td colspan="2"><b>Quantity (total)</b></td> <td>8</td> </tr> <tr> <td colspan="3"><b>Description:</b> Gable Wall Panel</td> </tr> </table> 	PRODUCT NUMBERS			A1	A2	A3	A4	A5	A6	A7	A8		<b>Quantity (total)</b>		8	<b>Description:</b> Gable Wall Panel			<table border="1"> <tr> <th>PRODUCT ID</th> <td>H</td> </tr> <tr> <td><b>Length</b></td> <td>1008mm</td> </tr> <tr> <td><b>Quantity</b></td> <td>2</td> </tr> <tr> <td colspan="2"><b>Description:</b> Door Frame Top/Bottom</td> </tr> </table> 	PRODUCT ID	H	<b>Length</b>	1008mm	<b>Quantity</b>	2	<b>Description:</b> Door Frame Top/Bottom	
PRODUCT NUMBERS																											
A1	A2	A3																									
A4	A5	A6																									
A7	A8																										
<b>Quantity (total)</b>		8																									
<b>Description:</b> Gable Wall Panel																											
PRODUCT ID	H																										
<b>Length</b>	1008mm																										
<b>Quantity</b>	2																										
<b>Description:</b> Door Frame Top/Bottom																											
<table border="1"> <tr> <th colspan="3">PRODUCT NUMBERS</th> </tr> <tr> <td>B1</td> <td>B2</td> <td>B3</td> </tr> <tr> <td>B4</td> <td>B5</td> <td>B6</td> </tr> <tr> <td>B7</td> <td>B8</td> <td></td> </tr> <tr> <td colspan="2"><b>Quantity (total)</b></td> <td>8</td> </tr> <tr> <td colspan="3"><b>Description:</b> Gable Wall Panel</td> </tr> </table> 	PRODUCT NUMBERS			B1	B2	B3	B4	B5	B6	B7	B8		<b>Quantity (total)</b>		8	<b>Description:</b> Gable Wall Panel			<table border="1"> <tr> <th>PRODUCT ID</th> <td>I</td> </tr> <tr> <td><b>Length</b></td> <td>1742mm</td> </tr> <tr> <td><b>Quantity</b></td> <td>2</td> </tr> <tr> <td colspan="2"><b>Description:</b> Door Frame Side</td> </tr> </table> 	PRODUCT ID	I	<b>Length</b>	1742mm	<b>Quantity</b>	2	<b>Description:</b> Door Frame Side	
PRODUCT NUMBERS																											
B1	B2	B3																									
B4	B5	B6																									
B7	B8																										
<b>Quantity (total)</b>		8																									
<b>Description:</b> Gable Wall Panel																											
PRODUCT ID	I																										
<b>Length</b>	1742mm																										
<b>Quantity</b>	2																										
<b>Description:</b> Door Frame Side																											
<table border="1"> <tr> <th>PRODUCT ID</th> <td>C</td> </tr> <tr> <td><b>Length</b></td> <td>1800mm</td> </tr> <tr> <td><b>Quantity</b></td> <td>6</td> </tr> <tr> <td colspan="2"><b>Description:</b> Wall Panel</td> </tr> </table> 	PRODUCT ID	C	<b>Length</b>	1800mm	<b>Quantity</b>	6	<b>Description:</b> Wall Panel		<table border="1"> <tr> <th>PRODUCT ID</th> <td>J</td> </tr> <tr> <td><b>Length</b></td> <td>1706mm</td> </tr> <tr> <td><b>Quantity</b></td> <td>2</td> </tr> <tr> <td colspan="2"><b>Description:</b> Door Boxing</td> </tr> </table> 	PRODUCT ID	J	<b>Length</b>	1706mm	<b>Quantity</b>	2	<b>Description:</b> Door Boxing											
PRODUCT ID	C																										
<b>Length</b>	1800mm																										
<b>Quantity</b>	6																										
<b>Description:</b> Wall Panel																											
PRODUCT ID	J																										
<b>Length</b>	1706mm																										
<b>Quantity</b>	2																										
<b>Description:</b> Door Boxing																											
<table border="1"> <tr> <th>PRODUCT ID</th> <td>D</td> </tr> <tr> <td><b>Length</b></td> <td>1800mm</td> </tr> <tr> <td><b>Quantity</b></td> <td>3</td> </tr> <tr> <td colspan="2"><b>Description:</b> Wall Corner Panels</td> </tr> </table> 	PRODUCT ID	D	<b>Length</b>	1800mm	<b>Quantity</b>	3	<b>Description:</b> Wall Corner Panels		<table border="1"> <tr> <th>PRODUCT ID</th> <td>K</td> </tr> <tr> <td><b>Length</b></td> <td>1280mm</td> </tr> <tr> <td><b>Quantity</b></td> <td>2</td> </tr> <tr> <td colspan="2"><b>Description:</b> Door Bracing</td> </tr> </table> 	PRODUCT ID	K	<b>Length</b>	1280mm	<b>Quantity</b>	2	<b>Description:</b> Door Bracing											
PRODUCT ID	D																										
<b>Length</b>	1800mm																										
<b>Quantity</b>	3																										
<b>Description:</b> Wall Corner Panels																											
PRODUCT ID	K																										
<b>Length</b>	1280mm																										
<b>Quantity</b>	2																										
<b>Description:</b> Door Bracing																											
<table border="1"> <tr> <th>PRODUCT ID</th> <td>E</td> </tr> <tr> <td><b>Length</b></td> <td>1454mm</td> </tr> <tr> <td><b>Quantity</b></td> <td>12</td> </tr> <tr> <td colspan="2"><b>Description:</b> Roof Panels</td> </tr> </table> 	PRODUCT ID	E	<b>Length</b>	1454mm	<b>Quantity</b>	12	<b>Description:</b> Roof Panels		<table border="1"> <tr> <th>PRODUCT ID</th> <td>M</td> </tr> <tr> <td><b>Length</b></td> <td>2099mm</td> </tr> <tr> <td><b>Quantity</b></td> <td>4</td> </tr> <tr> <td colspan="2"><b>Description:</b> Top/Bottom Front/Rear Channel</td> </tr> </table> 	PRODUCT ID	M	<b>Length</b>	2099mm	<b>Quantity</b>	4	<b>Description:</b> Top/Bottom Front/Rear Channel											
PRODUCT ID	E																										
<b>Length</b>	1454mm																										
<b>Quantity</b>	12																										
<b>Description:</b> Roof Panels																											
PRODUCT ID	M																										
<b>Length</b>	2099mm																										
<b>Quantity</b>	4																										
<b>Description:</b> Top/Bottom Front/Rear Channel																											
<table border="1"> <tr> <th>PRODUCT ID</th> <td>F</td> </tr> <tr> <td><b>Length</b></td> <td>1738mm</td> </tr> <tr> <td><b>Quantity</b></td> <td>2</td> </tr> <tr> <td colspan="2"><b>Description:</b> Door Panel (Partially slit)</td> </tr> </table> 	PRODUCT ID	F	<b>Length</b>	1738mm	<b>Quantity</b>	2	<b>Description:</b> Door Panel (Partially slit)		<table border="1"> <tr> <th>PRODUCT ID</th> <td>N</td> </tr> <tr> <td><b>Length</b></td> <td>2791mm (=1481+1480)</td> </tr> <tr> <td><b>Quantity</b></td> <td>2</td> </tr> <tr> <td colspan="2"><b>Description:</b> Side Channel Gable Bottom</td> </tr> </table> 	PRODUCT ID	N	<b>Length</b>	2791mm (=1481+1480)	<b>Quantity</b>	2	<b>Description:</b> Side Channel Gable Bottom											
PRODUCT ID	F																										
<b>Length</b>	1738mm																										
<b>Quantity</b>	2																										
<b>Description:</b> Door Panel (Partially slit)																											
PRODUCT ID	N																										
<b>Length</b>	2791mm (=1481+1480)																										
<b>Quantity</b>	2																										
<b>Description:</b> Side Channel Gable Bottom																											
<table border="1"> <tr> <th>PRODUCT ID</th> <td>G</td> </tr> <tr> <td><b>Length</b></td> <td>1738mm</td> </tr> <tr> <td><b>Quantity</b></td> <td>1</td> </tr> <tr> <td colspan="2"><b>Description:</b> Door Panel Centre</td> </tr> </table> 	PRODUCT ID	G	<b>Length</b>	1738mm	<b>Quantity</b>	1	<b>Description:</b> Door Panel Centre		<table border="1"> <tr> <th>PRODUCT ID</th> <td>O</td> </tr> <tr> <td><b>Length</b></td> <td>1411mm</td> </tr> <tr> <td><b>Quantity</b></td> <td>2</td> </tr> <tr> <td colspan="2"><b>Description:</b> Side Channel Gable Top</td> </tr> </table> 	PRODUCT ID	O	<b>Length</b>	1411mm	<b>Quantity</b>	2	<b>Description:</b> Side Channel Gable Top											
PRODUCT ID	G																										
<b>Length</b>	1738mm																										
<b>Quantity</b>	1																										
<b>Description:</b> Door Panel Centre																											
PRODUCT ID	O																										
<b>Length</b>	1411mm																										
<b>Quantity</b>	2																										
<b>Description:</b> Side Channel Gable Top																											

# PARTS LIST

<table border="1"> <tr><td><b>PRODUCT ID</b></td><td><b>P</b></td></tr> <tr><td><b>Length</b></td><td>1415mm</td></tr> <tr><td><b>Quantity</b></td><td>2</td></tr> <tr><td><b>Description:</b></td><td>Side Channel Gable Top</td></tr> </table>	<b>PRODUCT ID</b>	<b>P</b>	<b>Length</b>	1415mm	<b>Quantity</b>	2	<b>Description:</b>	Side Channel Gable Top		<table border="1"> <tr><td><b>PRODUCT ID</b></td><td><b>W</b></td></tr> <tr><td><b>Length</b></td><td>1446mm</td></tr> <tr><td><b>Quantity</b></td><td>2</td></tr> <tr><td><b>Description:</b></td><td>Roof Angle Trim</td></tr> </table>	<b>PRODUCT ID</b>	<b>W</b>	<b>Length</b>	1446mm	<b>Quantity</b>	2	<b>Description:</b>	Roof Angle Trim	
<b>PRODUCT ID</b>	<b>P</b>																		
<b>Length</b>	1415mm																		
<b>Quantity</b>	2																		
<b>Description:</b>	Side Channel Gable Top																		
<b>PRODUCT ID</b>	<b>W</b>																		
<b>Length</b>	1446mm																		
<b>Quantity</b>	2																		
<b>Description:</b>	Roof Angle Trim																		
<table border="1"> <tr><td><b>PRODUCT ID</b></td><td><b>Q</b></td></tr> <tr><td><b>Length</b></td><td>1800mm</td></tr> <tr><td><b>Quantity</b></td><td>2</td></tr> <tr><td><b>Description:</b></td><td>Door Jamb</td></tr> </table>	<b>PRODUCT ID</b>	<b>Q</b>	<b>Length</b>	1800mm	<b>Quantity</b>	2	<b>Description:</b>	Door Jamb		<table border="1"> <tr><td><b>PRODUCT ID</b></td><td><b>W</b></td></tr> <tr><td><b>Length</b></td><td>1443mm</td></tr> <tr><td><b>Quantity</b></td><td>2</td></tr> <tr><td><b>Description:</b></td><td>Roof Angle Trim</td></tr> </table>	<b>PRODUCT ID</b>	<b>W</b>	<b>Length</b>	1443mm	<b>Quantity</b>	2	<b>Description:</b>	Roof Angle Trim	
<b>PRODUCT ID</b>	<b>Q</b>																		
<b>Length</b>	1800mm																		
<b>Quantity</b>	2																		
<b>Description:</b>	Door Jamb																		
<b>PRODUCT ID</b>	<b>W</b>																		
<b>Length</b>	1443mm																		
<b>Quantity</b>	2																		
<b>Description:</b>	Roof Angle Trim																		
<table border="1"> <tr><td><b>PRODUCT ID</b></td><td><b>R</b></td></tr> <tr><td><b>Length</b></td><td>1021mm</td></tr> <tr><td><b>Quantity</b></td><td>1</td></tr> <tr><td><b>Description:</b></td><td>Bottom Door Spacer</td></tr> </table>	<b>PRODUCT ID</b>	<b>R</b>	<b>Length</b>	1021mm	<b>Quantity</b>	1	<b>Description:</b>	Bottom Door Spacer		<table border="1"> <tr><td><b>Quantity</b></td><td>400</td></tr> <tr><td><b>Description:</b></td><td>Self Tapping Screws - Silver</td></tr> </table>	<b>Quantity</b>	400	<b>Description:</b>	Self Tapping Screws - Silver					
<b>PRODUCT ID</b>	<b>R</b>																		
<b>Length</b>	1021mm																		
<b>Quantity</b>	1																		
<b>Description:</b>	Bottom Door Spacer																		
<b>Quantity</b>	400																		
<b>Description:</b>	Self Tapping Screws - Silver																		
<table border="1"> <tr><td><b>PRODUCT ID</b></td><td><b>S</b></td></tr> <tr><td><b>Length</b></td><td>1021mm</td></tr> <tr><td><b>Quantity</b></td><td>1</td></tr> <tr><td><b>Description:</b></td><td>Top Door Spacer</td></tr> </table>	<b>PRODUCT ID</b>	<b>S</b>	<b>Length</b>	1021mm	<b>Quantity</b>	1	<b>Description:</b>	Top Door Spacer		<table border="1"> <tr><td><b>Quantity</b></td><td>1</td></tr> <tr><td><b>Description:</b></td><td>2.5mm Drill Bit</td></tr> </table>	<b>Quantity</b>	1	<b>Description:</b>	2.5mm Drill Bit					
<b>PRODUCT ID</b>	<b>S</b>																		
<b>Length</b>	1021mm																		
<b>Quantity</b>	1																		
<b>Description:</b>	Top Door Spacer																		
<b>Quantity</b>	1																		
<b>Description:</b>	2.5mm Drill Bit																		
<table border="1"> <tr><td><b>PRODUCT ID</b></td><td><b>T</b></td></tr> <tr><td><b>Length</b></td><td>1364mm</td></tr> <tr><td><b>Quantity</b></td><td>4</td></tr> <tr><td><b>Description:</b></td><td>Ridge Beam</td></tr> </table>	<b>PRODUCT ID</b>	<b>T</b>	<b>Length</b>	1364mm	<b>Quantity</b>	4	<b>Description:</b>	Ridge Beam		<table border="1"> <tr><td><b>Quantity</b></td><td>2</td></tr> <tr><td><b>Description:</b></td><td>Hinges (offset)</td></tr> </table>	<b>Quantity</b>	2	<b>Description:</b>	Hinges (offset)					
<b>PRODUCT ID</b>	<b>T</b>																		
<b>Length</b>	1364mm																		
<b>Quantity</b>	4																		
<b>Description:</b>	Ridge Beam																		
<b>Quantity</b>	2																		
<b>Description:</b>	Hinges (offset)																		
<table border="1"> <tr><td><b>PRODUCT ID</b></td><td><b>U</b></td></tr> <tr><td><b>Length</b></td><td>708mm</td></tr> <tr><td><b>Quantity</b></td><td>3</td></tr> <tr><td><b>Description:</b></td><td>Ridge Cap</td></tr> </table>	<b>PRODUCT ID</b>	<b>U</b>	<b>Length</b>	708mm	<b>Quantity</b>	3	<b>Description:</b>	Ridge Cap		<table border="1"> <tr><td><b>Quantity</b></td><td>1</td></tr> <tr><td><b>Description:</b></td><td>Padbolt</td></tr> </table>	<b>Quantity</b>	1	<b>Description:</b>	Padbolt					
<b>PRODUCT ID</b>	<b>U</b>																		
<b>Length</b>	708mm																		
<b>Quantity</b>	3																		
<b>Description:</b>	Ridge Cap																		
<b>Quantity</b>	1																		
<b>Description:</b>	Padbolt																		
<table border="1"> <tr><td><b>PRODUCT ID</b></td><td><b>V</b></td></tr> <tr><td><b>Length</b></td><td>2096mm</td></tr> <tr><td><b>Quantity</b></td><td>2</td></tr> <tr><td><b>Description:</b></td><td>Gutter Trim</td></tr> </table>	<b>PRODUCT ID</b>	<b>V</b>	<b>Length</b>	2096mm	<b>Quantity</b>	2	<b>Description:</b>	Gutter Trim		<table border="1"> <tr><td><b>Quantity</b></td><td>1</td></tr> <tr><td><b>Description:</b></td><td>Keeper</td></tr> </table>	<b>Quantity</b>	1	<b>Description:</b>	Keeper					
<b>PRODUCT ID</b>	<b>V</b>																		
<b>Length</b>	2096mm																		
<b>Quantity</b>	2																		
<b>Description:</b>	Gutter Trim																		
<b>Quantity</b>	1																		
<b>Description:</b>	Keeper																		

# PARTS LIST

<table border="1"> <tr> <td><b>Quantity</b></td> <td>4</td> </tr> <tr> <td colspan="2"><b>Description:</b> Plastic Corner Cap</td> </tr> </table>	<b>Quantity</b>	4	<b>Description:</b> Plastic Corner Cap			<table border="1"> <tr> <td><b>Quantity</b></td> <td>2</td> </tr> <tr> <td colspan="2"><b>Description:</b> Plastic Washer and Screw Cap Sheet</td> </tr> </table>	<b>Quantity</b>	2	<b>Description:</b> Plastic Washer and Screw Cap Sheet		
<b>Quantity</b>	4										
<b>Description:</b> Plastic Corner Cap											
<b>Quantity</b>	2										
<b>Description:</b> Plastic Washer and Screw Cap Sheet											
<table border="1"> <tr> <td><b>Quantity</b></td> <td>2</td> </tr> <tr> <td colspan="2"><b>Description:</b> Plastic Ridge End Cap</td> </tr> </table>	<b>Quantity</b>	2	<b>Description:</b> Plastic Ridge End Cap			<table border="1"> <tr> <td><b>Quantity</b></td> <td>2</td> </tr> <tr> <td colspan="2"><b>Description:</b> Ridge Beam Bracket</td> </tr> </table>	<b>Quantity</b>	2	<b>Description:</b> Ridge Beam Bracket		
<b>Quantity</b>	2										
<b>Description:</b> Plastic Ridge End Cap											
<b>Quantity</b>	2										
<b>Description:</b> Ridge Beam Bracket											
<table border="1"> <tr> <td><b>Quantity</b></td> <td>4</td> </tr> <tr> <td colspan="2"><b>Description:</b> Corner Bracket</td> </tr> </table>	<b>Quantity</b>	4	<b>Description:</b> Corner Bracket			<table border="1"> <tr> <td><b>Quantity</b></td> <td>9</td> </tr> <tr> <td colspan="2"><b>Description:</b> Masonry Anchor</td> </tr> </table>	<b>Quantity</b>	9	<b>Description:</b> Masonry Anchor		
<b>Quantity</b>	4										
<b>Description:</b> Corner Bracket											
<b>Quantity</b>	9										
<b>Description:</b> Masonry Anchor											
<table border="1"> <tr> <td><b>Quantity</b></td> <td>5</td> </tr> <tr> <td colspan="2"><b>Description:</b> 55mm Bracket</td> </tr> </table>	<b>Quantity</b>	5	<b>Description:</b> 55mm Bracket			<table border="1"> <tr> <td><b>Quantity</b></td> <td>1</td> </tr> <tr> <td colspan="2"><b>Description:</b> Door Plate</td> </tr> </table>	<b>Quantity</b>	1	<b>Description:</b> Door Plate		
<b>Quantity</b>	5										
<b>Description:</b> 55mm Bracket											
<b>Quantity</b>	1										
<b>Description:</b> Door Plate											
<table border="1"> <tr> <td><b>Quantity</b></td> <td>10</td> </tr> <tr> <td colspan="2"><b>Description:</b> Nut &amp; Bolt 3/16"</td> </tr> </table>	<b>Quantity</b>	10	<b>Description:</b> Nut & Bolt 3/16"			<table border="1"> <tr> <td><b>Quantity</b></td> <td>2</td> </tr> <tr> <td colspan="2"><b>Description:</b> Clip Nut</td> </tr> </table>	<b>Quantity</b>	2	<b>Description:</b> Clip Nut		
<b>Quantity</b>	10										
<b>Description:</b> Nut & Bolt 3/16"											
<b>Quantity</b>	2										
<b>Description:</b> Clip Nut											
		<table border="1"> <tr> <td><b>Quantity</b></td> <td>1</td> </tr> <tr> <td colspan="2"><b>Description:</b> Phillips Head Bit</td> </tr> </table>	<b>Quantity</b>	1	<b>Description:</b> Phillips Head Bit						
<b>Quantity</b>	1										
<b>Description:</b> Phillips Head Bit											

## FOUNDATION

Recommended edge thickening

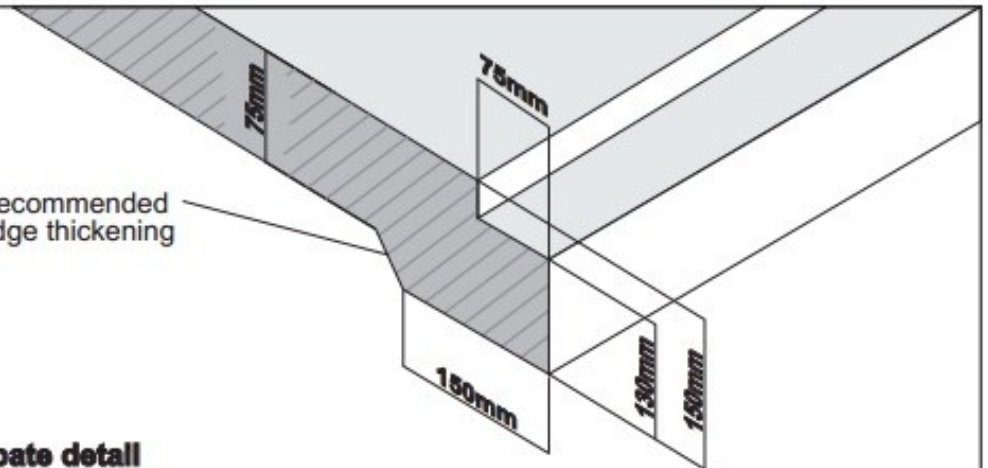

### Recommended slab rebate detail

Although *not required*, it is strongly recommended that, to avoid water leakage around the base of your shed, a rebate be cast into the slab. This will allow the shed to sit below the slab level and prevent water from reaching the upper level of the slab.

If you planning a rebated slab make sure to cut the 4 corners at  $125 \times 45^\circ$  as shown in detail below.

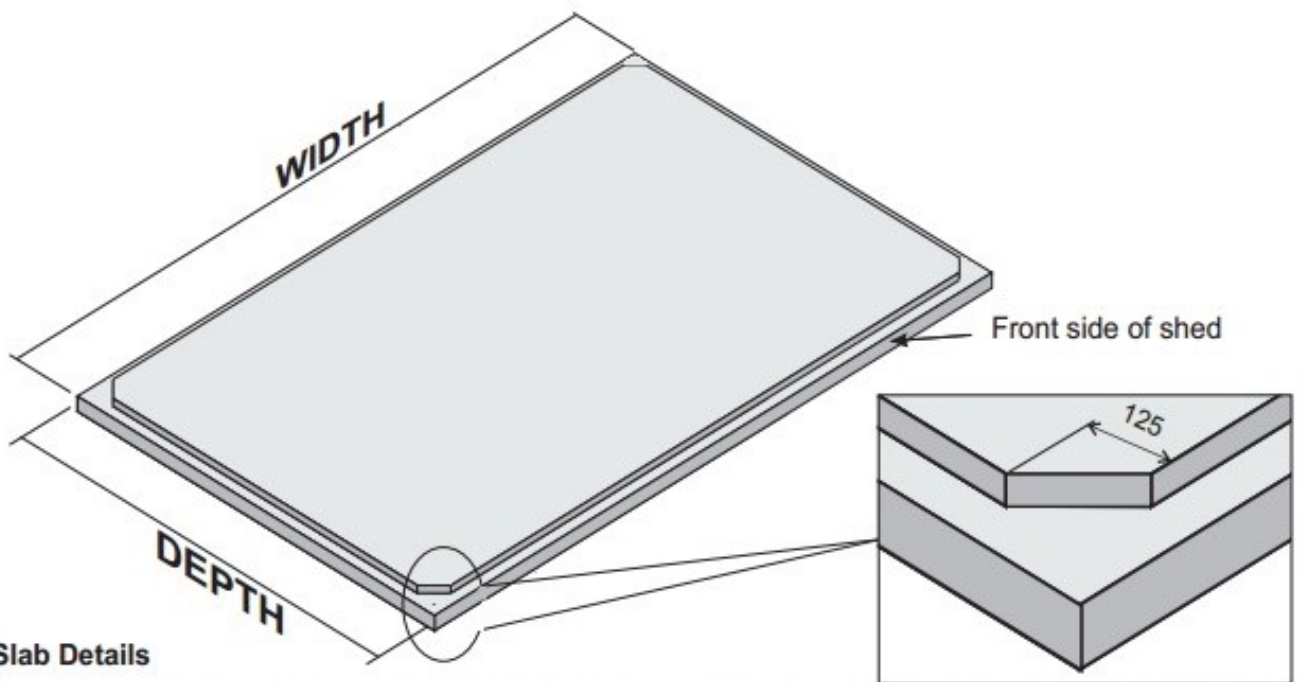

### Slab Details

Your garden shed must be erected on a solid, level and square foundation. We strongly recommend you pour a concrete slab 75mm thick, reinforced with SL62 mesh (minimum) using dimensions from the table below.

**\*Masonry anchors are supplied\***

SHED CODE	OUTER SLAB SIZE width x depth	ANCHORS M8 x 40mm
<b>68</b>	<b>2205mm x 2900mm</b>	<b>9</b>

## REAR WALL PANEL



If you are having trouble screwing the channel to the sheets, chock behind the hole.

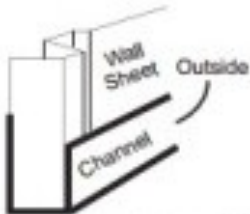

Ensure that the small lip of the channel is to the outside of the shed.

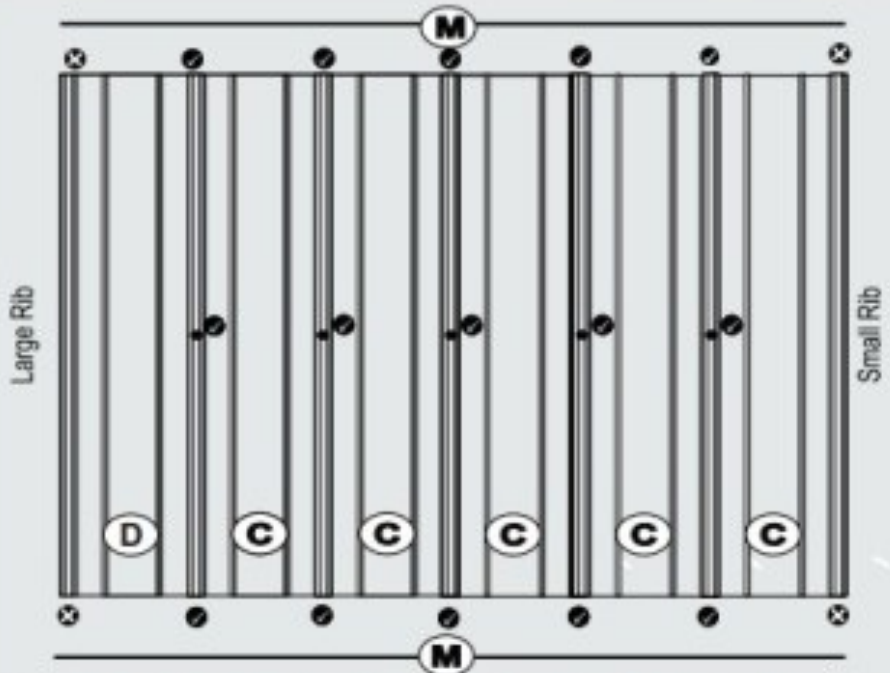
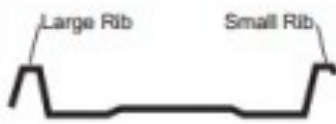

Fit the top and bottom channel to the wall panels. Ensure the channel is flush with the edge of the sheets. Do not screw the ends of the channel to the sheets at this point.

1

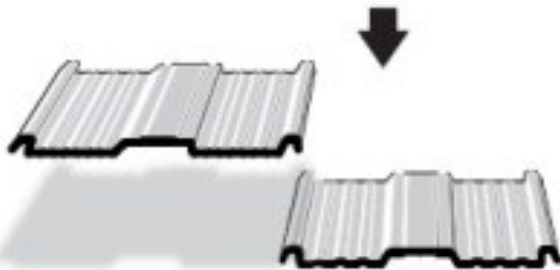

Lay the wall panels out with the large rib overlapping the small.



Screw the wall panels in the centre of the rib as shown.

2

Notched ends are orientated to the outer edges of the panel



Do not screw here yet



## FRONT WALL PANEL



If you are having trouble screwing the channel to the sheets, chock behind the hole .

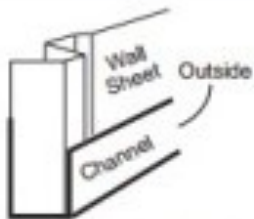

Ensure that the small lip of the channel is to the outside of the shed.

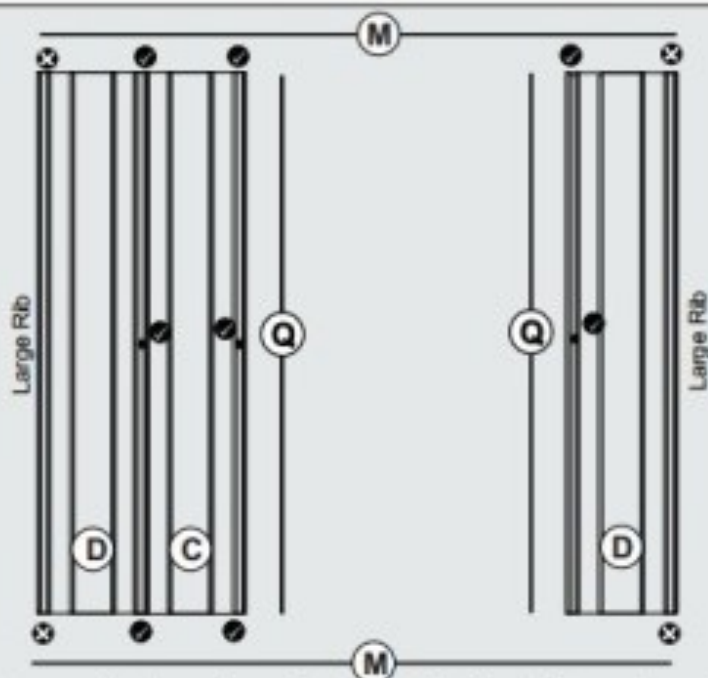

Fit the top and bottom channel and door jambs to the wall panels. Ensure the large rib on the sheets is to the left on the left side of the door and to the right on the right side of the door. Also ensure the channel is flush with the edge of the sheets. Do not screw the ends of the channel to the sheets at this point.

1 Notched ends are orientated to the outer edges of the panel

1



Large Lip overlaps Small Lip when fastening sheet to sheet

Do not screw here yet

X



2 Top and bottom door jamb connection.

2





## FRONT WALL PANEL

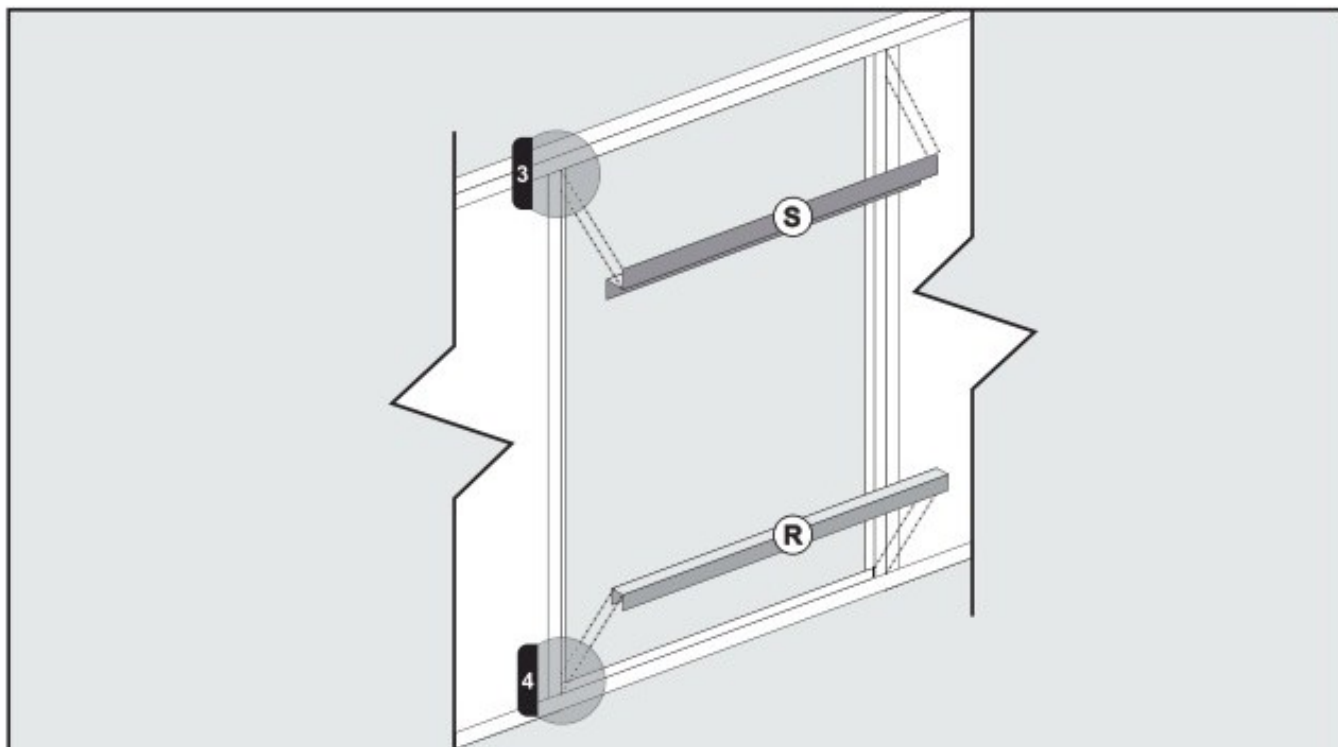

Fit the top door spacer and the bottom door spacer to the front wall panel as shown. Some pilot holes may need to be drilled with the included 2.5mm drill bit

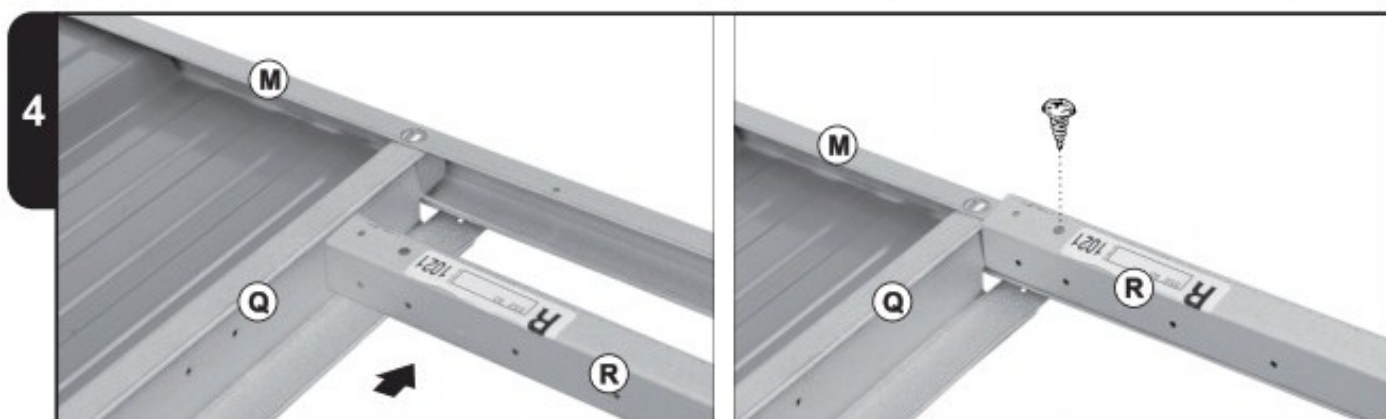
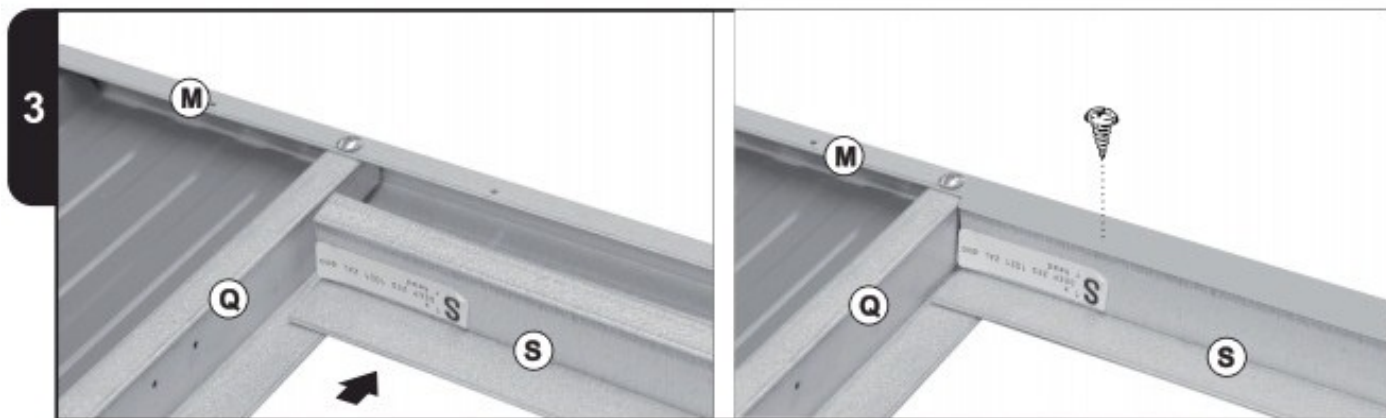

## FRONT WALL PANEL

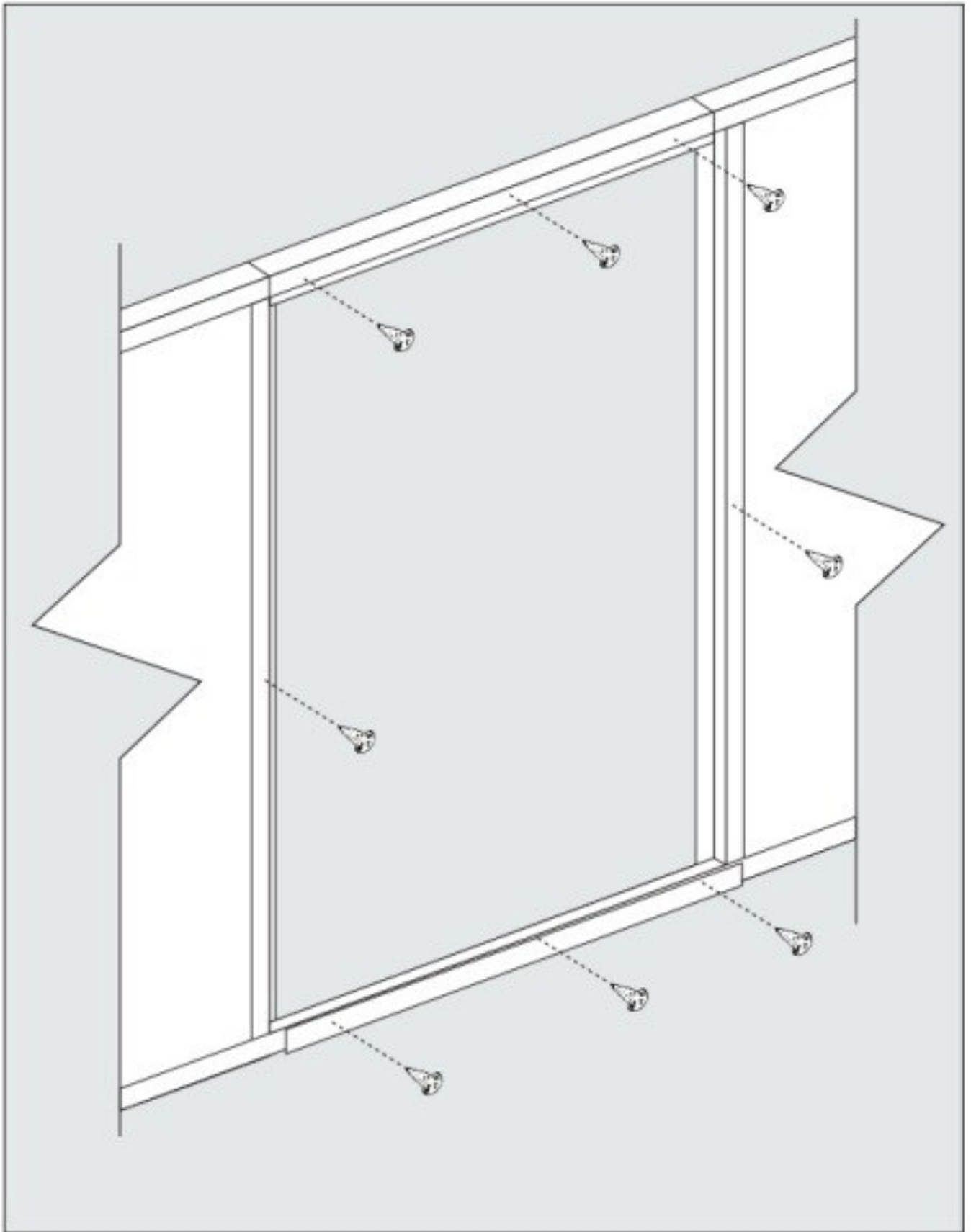

## GABLE WALL PANELS



If you are having trouble screwing the channel to the sheets, chock behind the hole .

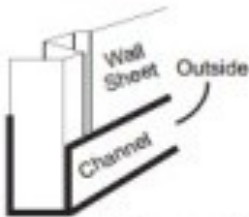

Ensure that the small lip of the channel is to the outside of the shed.

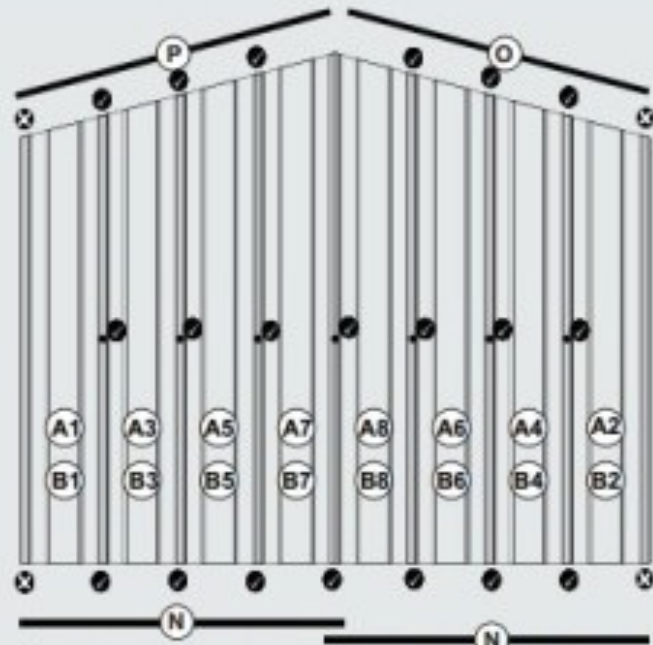

(A) Left Gable Panel Labels, (B) Right Gable Panel Labels

Overlap bottom channel by 130mm. Fit the top and bottom channel to the wall panels. Ensure the channel is flush with the edge of the sheets. Do not screw the ends of the channel to the sheets at this point.

1

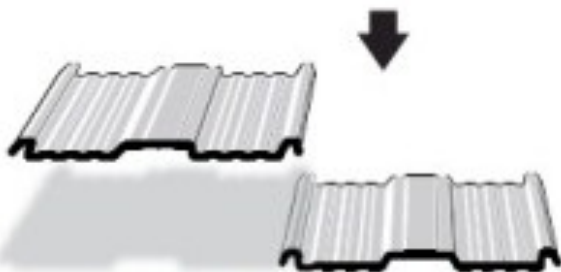

Lay the wall panels out with the large rib overlapping the small.



Screw the wall panels in the centre of the rib as shown.

2

Notched ends are orientated to the outer edges of the panel



Do not screw here yet



## FIT RIDGE BEAM BRACKETS

**NOTE:** The diagram below shows a 66 gable wall. The assembly process is the same for all gable sizes.

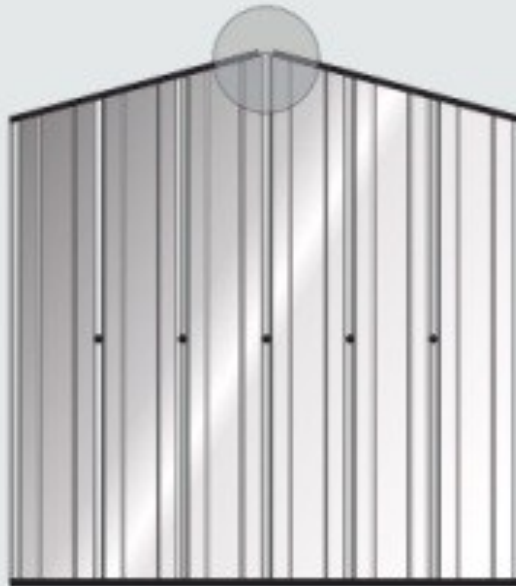

Fix the ridge beam brackets to the top of the gables using six (6) screws as shown below.

**1** Pre Drill holes from inside the gable wall, Then fix from outside with 4 screws.



Secure brackets with six (6) screws as shown on both gable walls.

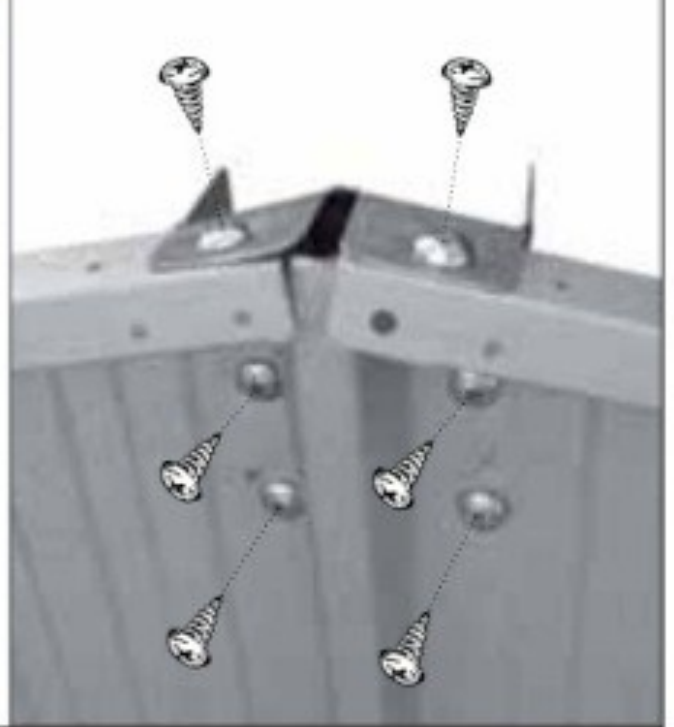

## STAND AND JOIN WALL PANELS

**NOTE:** The diagram below shows a 66 gable roof shed. The assembly process is the same for all gable roof sizes.

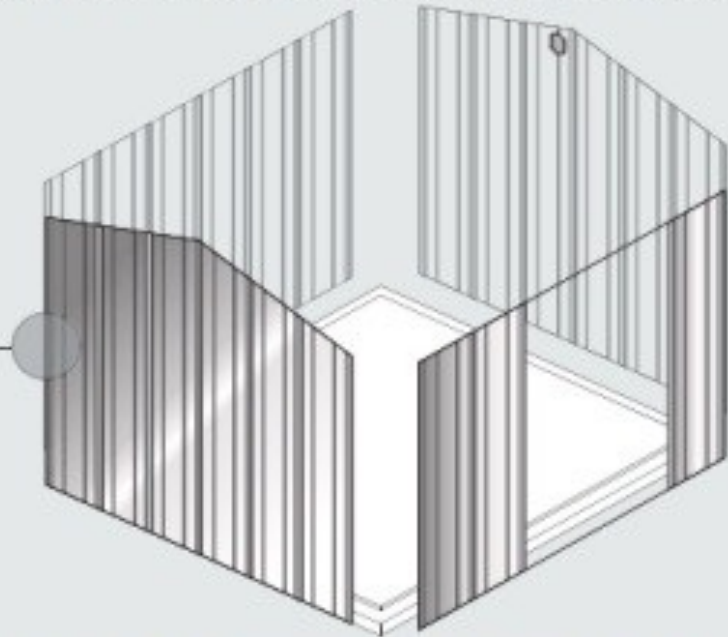
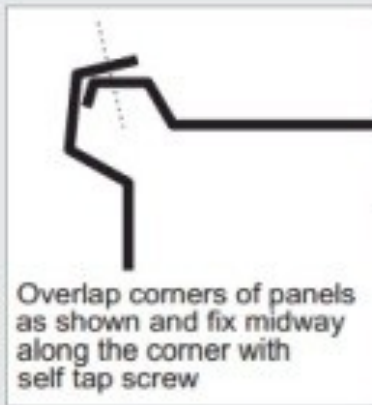

Once the four wall panels are assembled, they can now be stood and fixed together. Fix using the corner brackets and screws as shown below. Fix the front panel last. N.B when assembling large wall models, eg. 7 panels width and above, extra care should be taken, with person two providing adequate support to stop the wall from distorting.

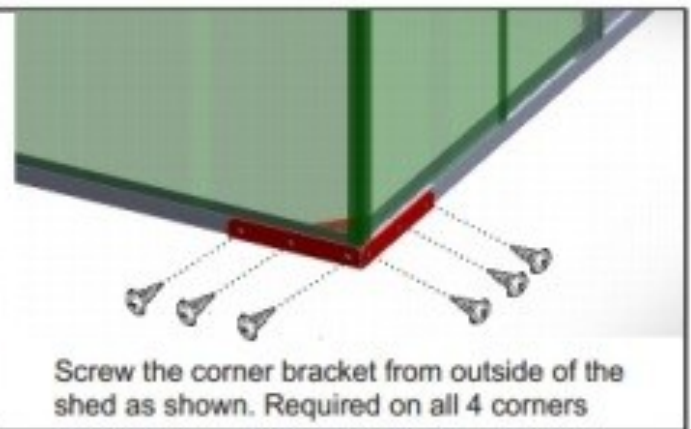
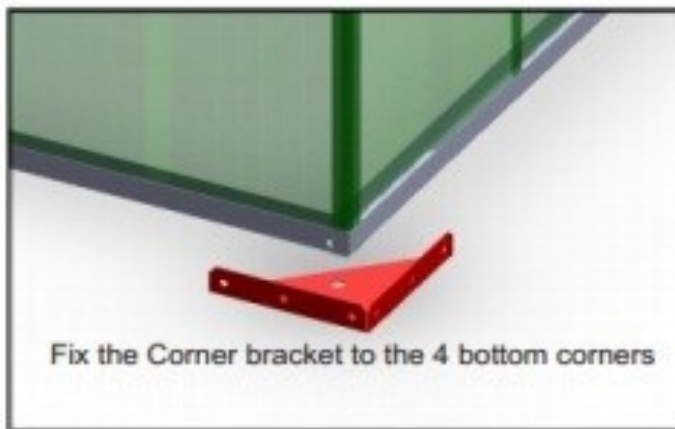

## ASSEMBLE AND FIT RIDGE BEAM

**NOTE:** The diagram below shows a 66 gable roof shed. The assembly process is the same for all gable roof sizes.

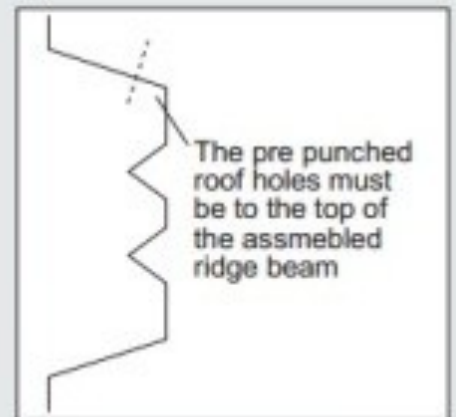
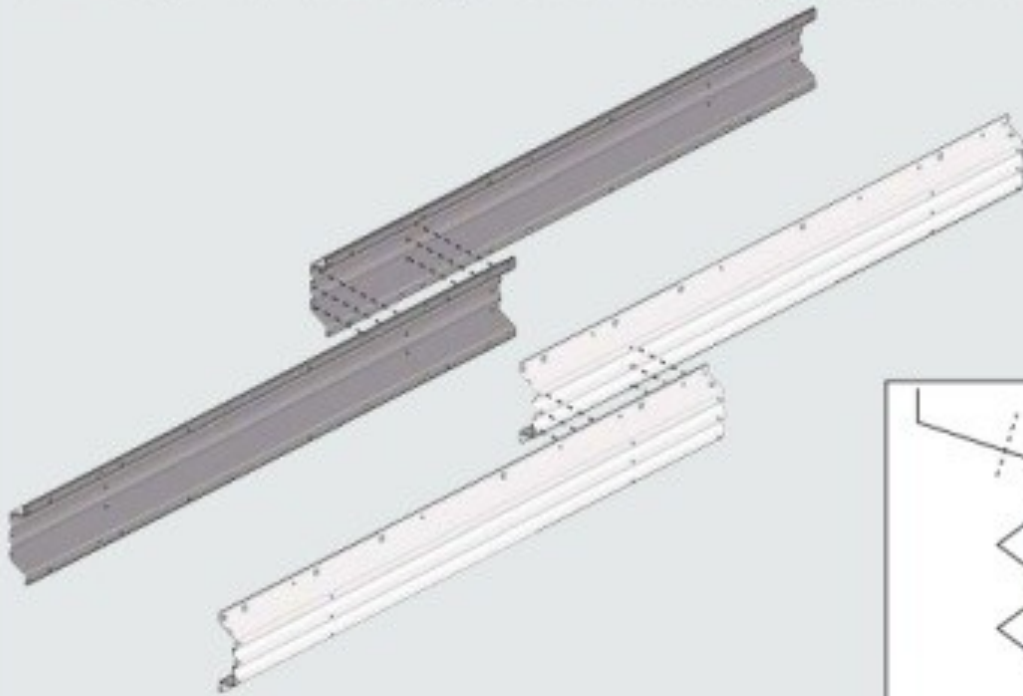

Assemble the ridge beam on the ground as shown below.

1

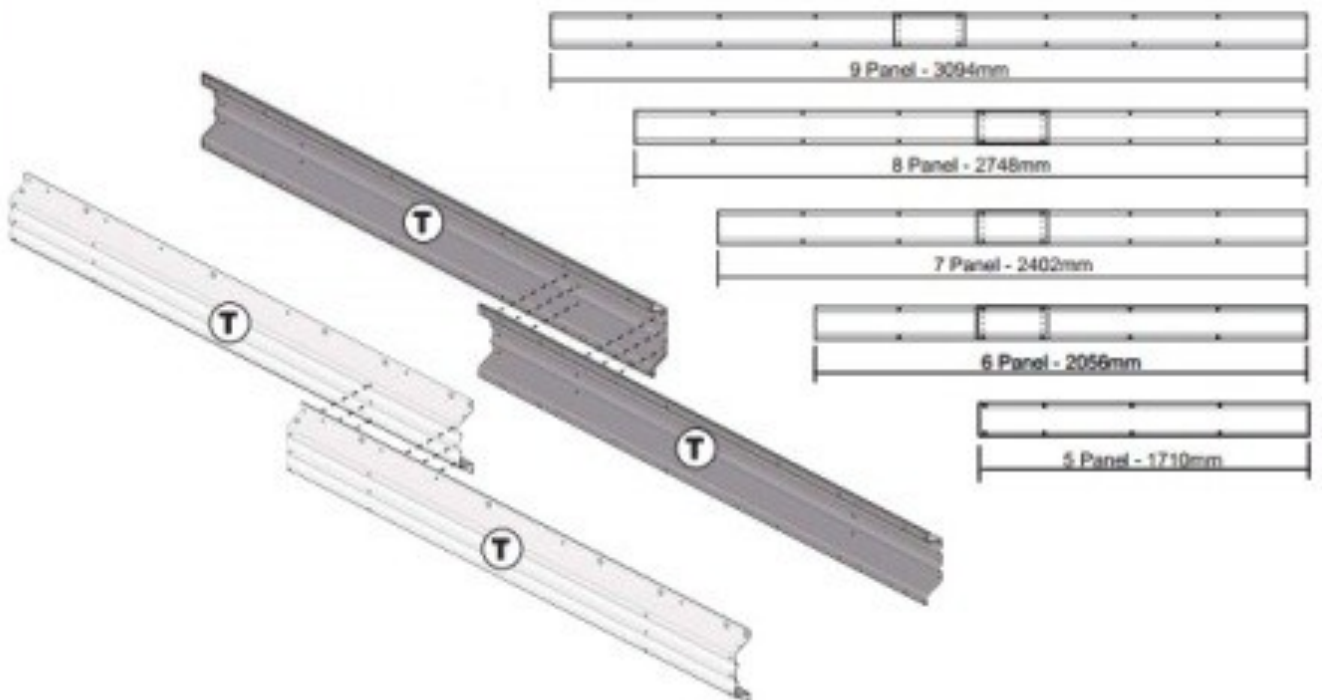

Overlap the two sides of the ridge beam securing them with six (6) screws per side. Ensure the pre-drilled roof panel holes are to the top. Screw the two sides together using the diagram top right as a guide. **Note:** The two halves of the ridge beam should be fixed at 346mm intervals.

## ASSEMBLE AND FIT RIDGE BEAM

**NOTE:** The diagram below shows a 66 gable roof shed. The assembly process is the same for all gable roof sizes.

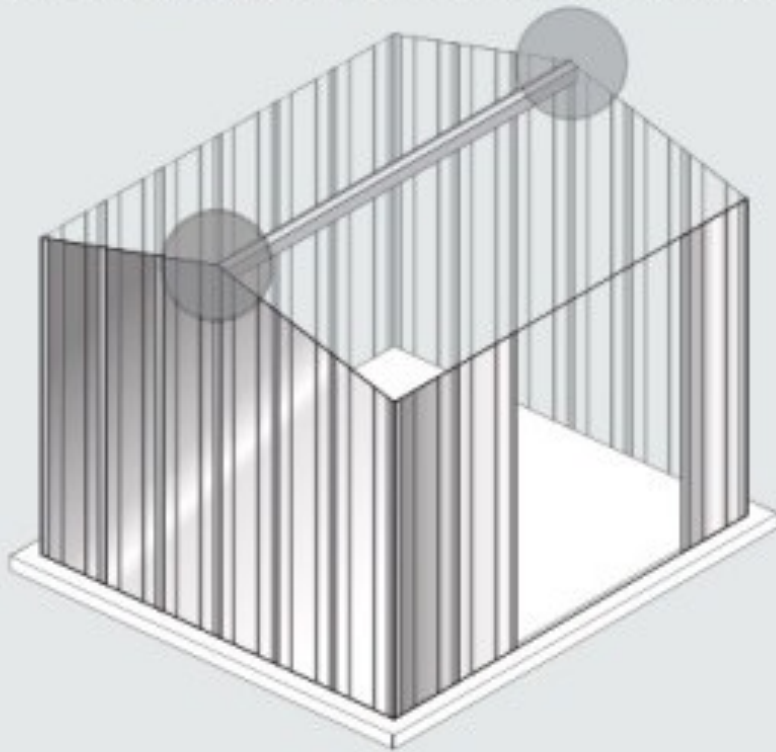

Fit the ridge beam to the two brackets as shown below.

2



Fit the ridge beam to the two brackets using three (3) screws on either side of the bracket.

## FIT ROOF AND TRIMS

1

Screw the door side of the roof on first (do not start the rear side yet). Work from right to left ensuring the large rib is over the small rib. (If you are installing a skylight, please refer to the instructions at the end of this booklet)

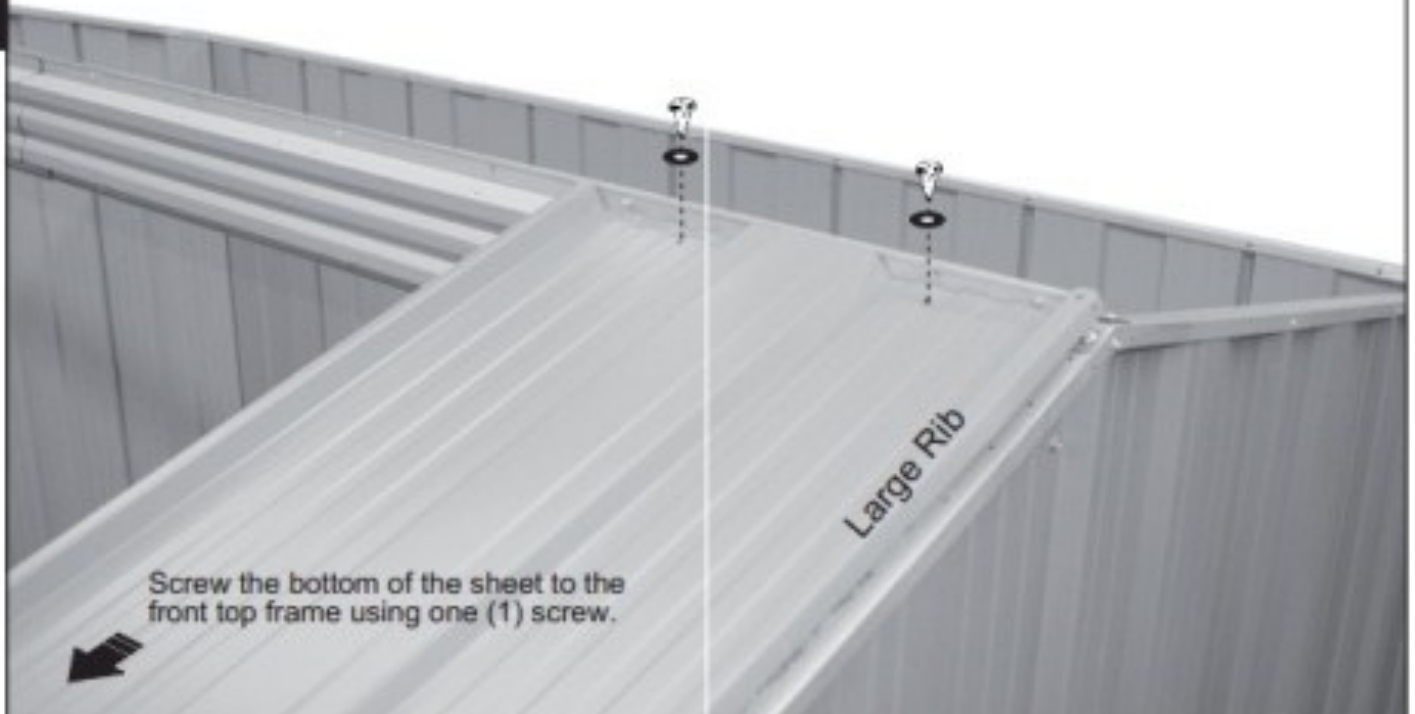

2

Fix the first two (2) sheets of the rear side then place the first ridge cap (do not screw at this stage).

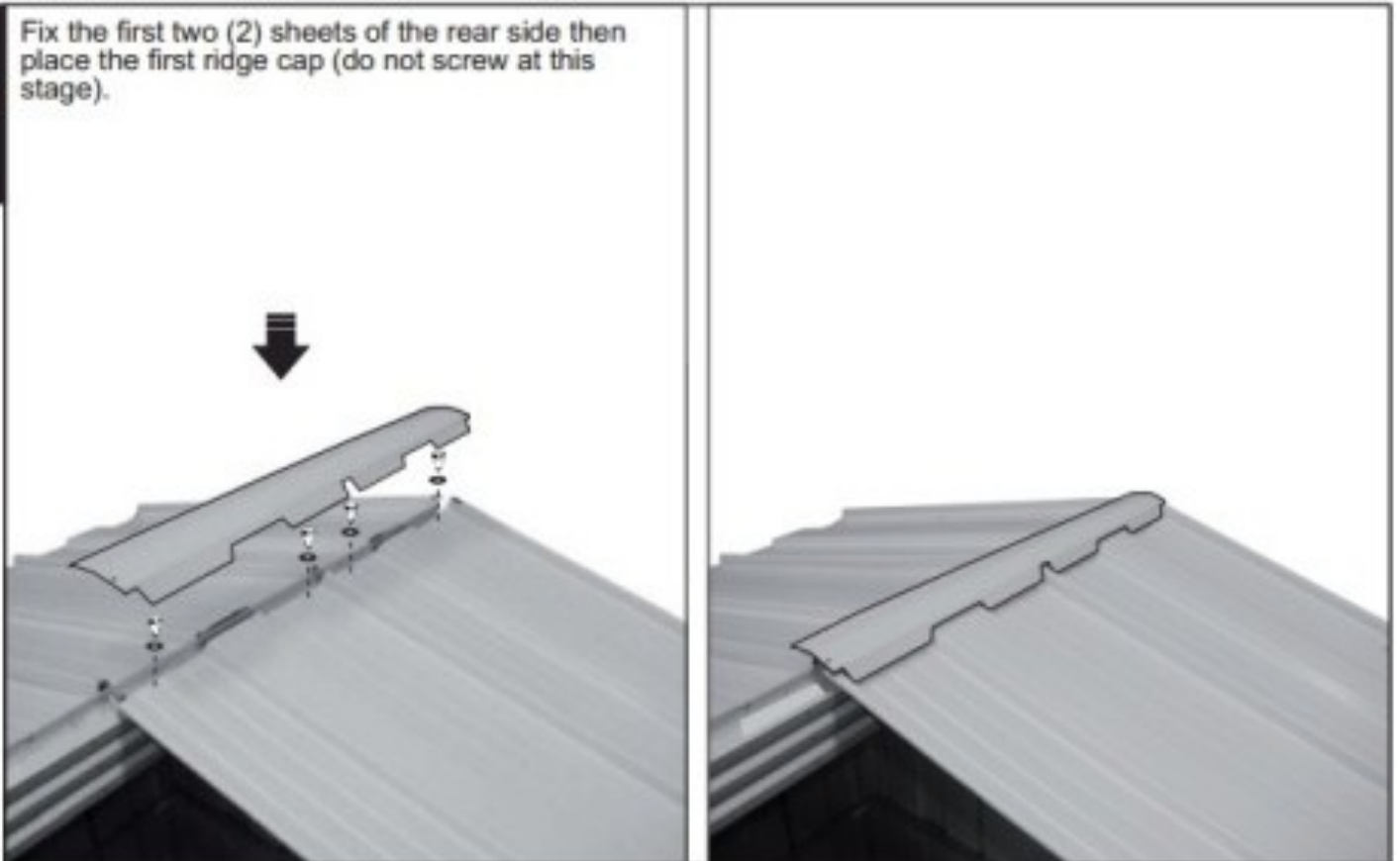



## FIT ROOF AND TRIMS

3

Fix the next two (2) sheets then fit the second ridge cap. Fix this as shown to the right.

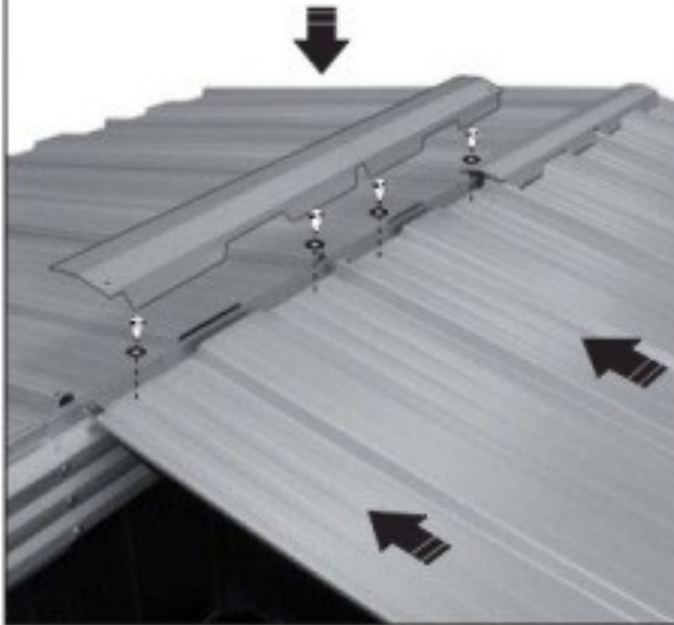

Finish the roof in the same manner.



4



Push Roof trim into one end first and then manipulate the roof trim to fit the other



# ASSEMBLE DOOR

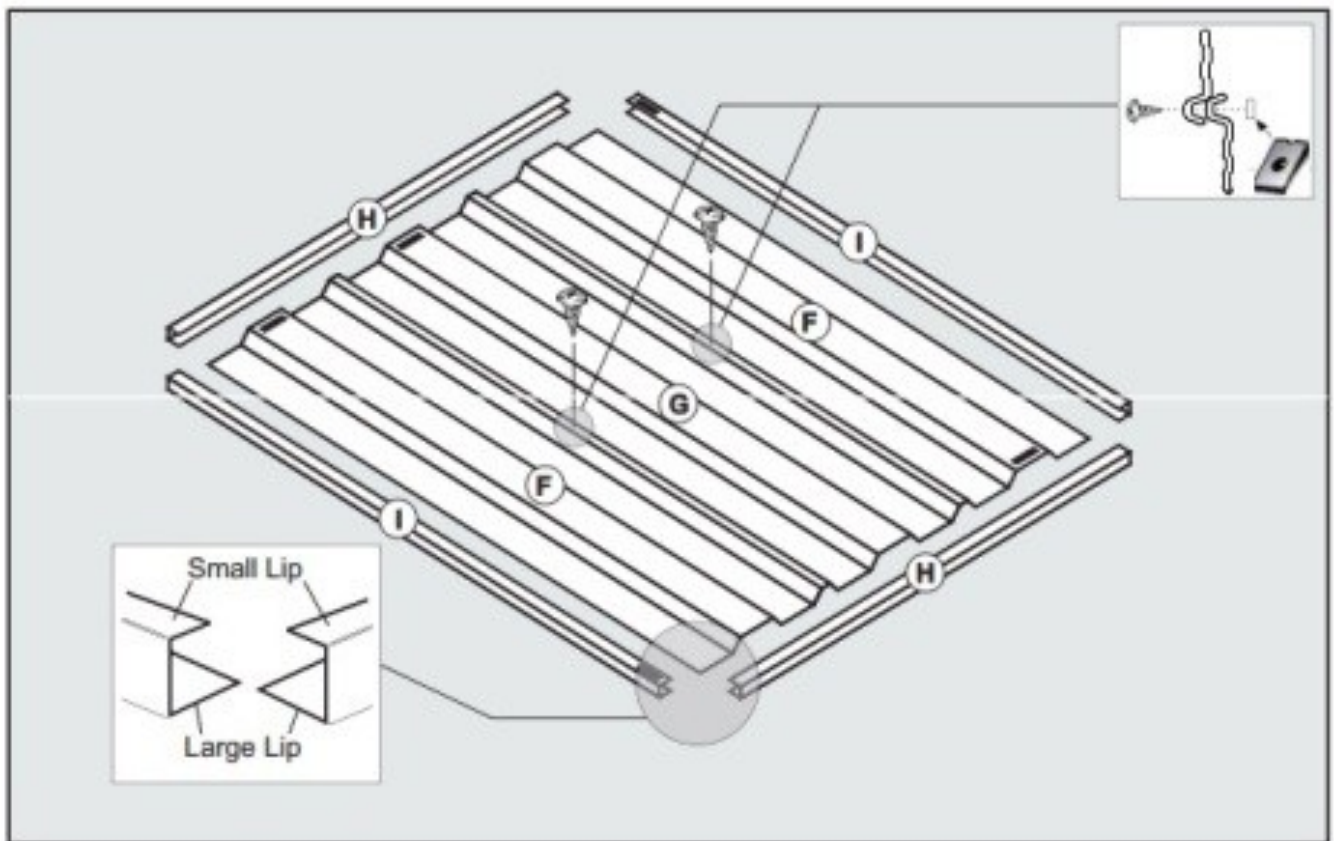

1



Two of the door sheets come with one rib partially slit. Break them off and discard them.



Screw the sheets in the centre.

2

Frames slide under the sheet as shown. Ensure the small lip of the frame is to the top.



Fix door frames with a screw in each corner. Ensure that the big hole sits over the small.



## ASSEMBLE DOOR

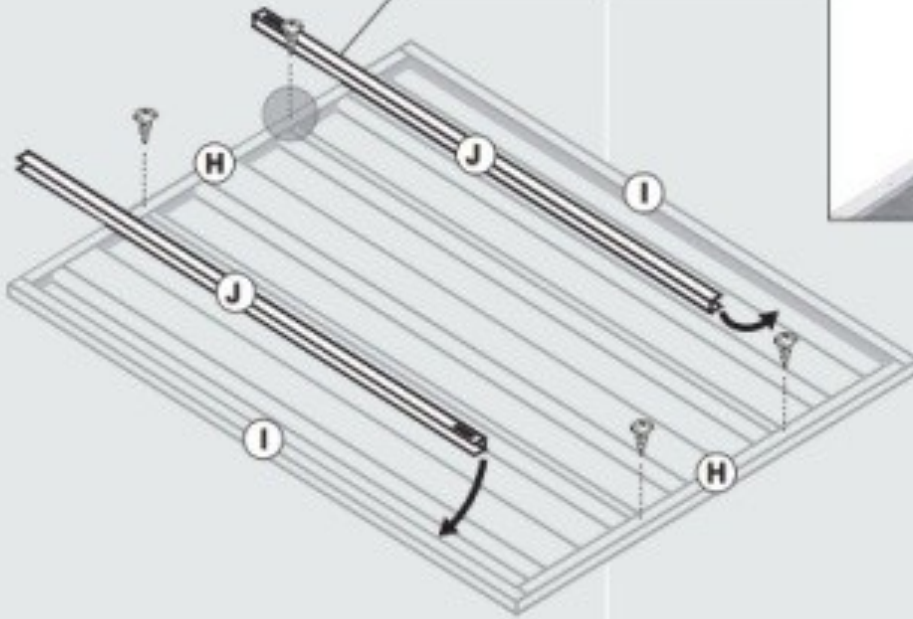

Fix the frame H to the sheeting with screws through the small channel lips into the large sheeting ribs. Door boxing must be fitted to the door frame.

3

Leave an even gap at both ends of the boxing.

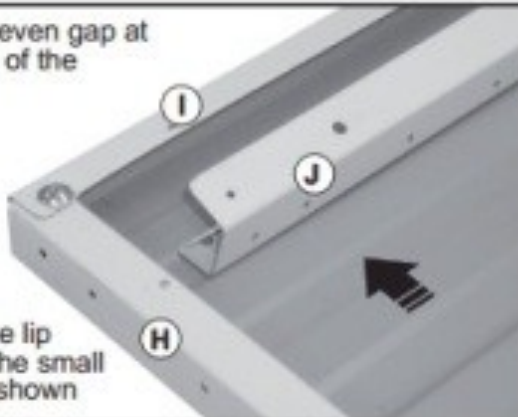

Place large lip of J over the small lip of I as shown

Screw the boxing to the frame as shown to the right

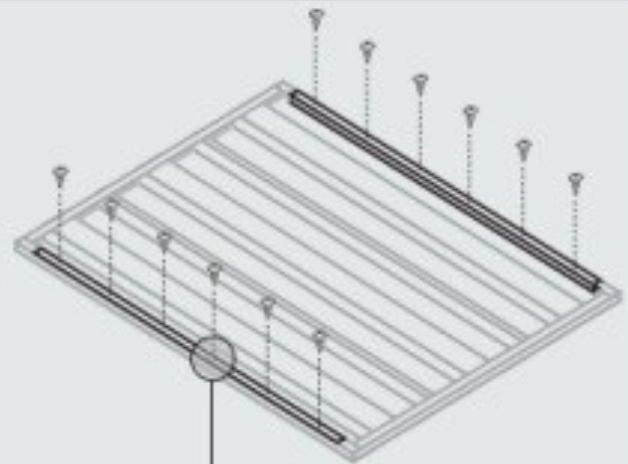

Fix both door boxing in place using six (6) screws.

## ASSEMBLE DOOR

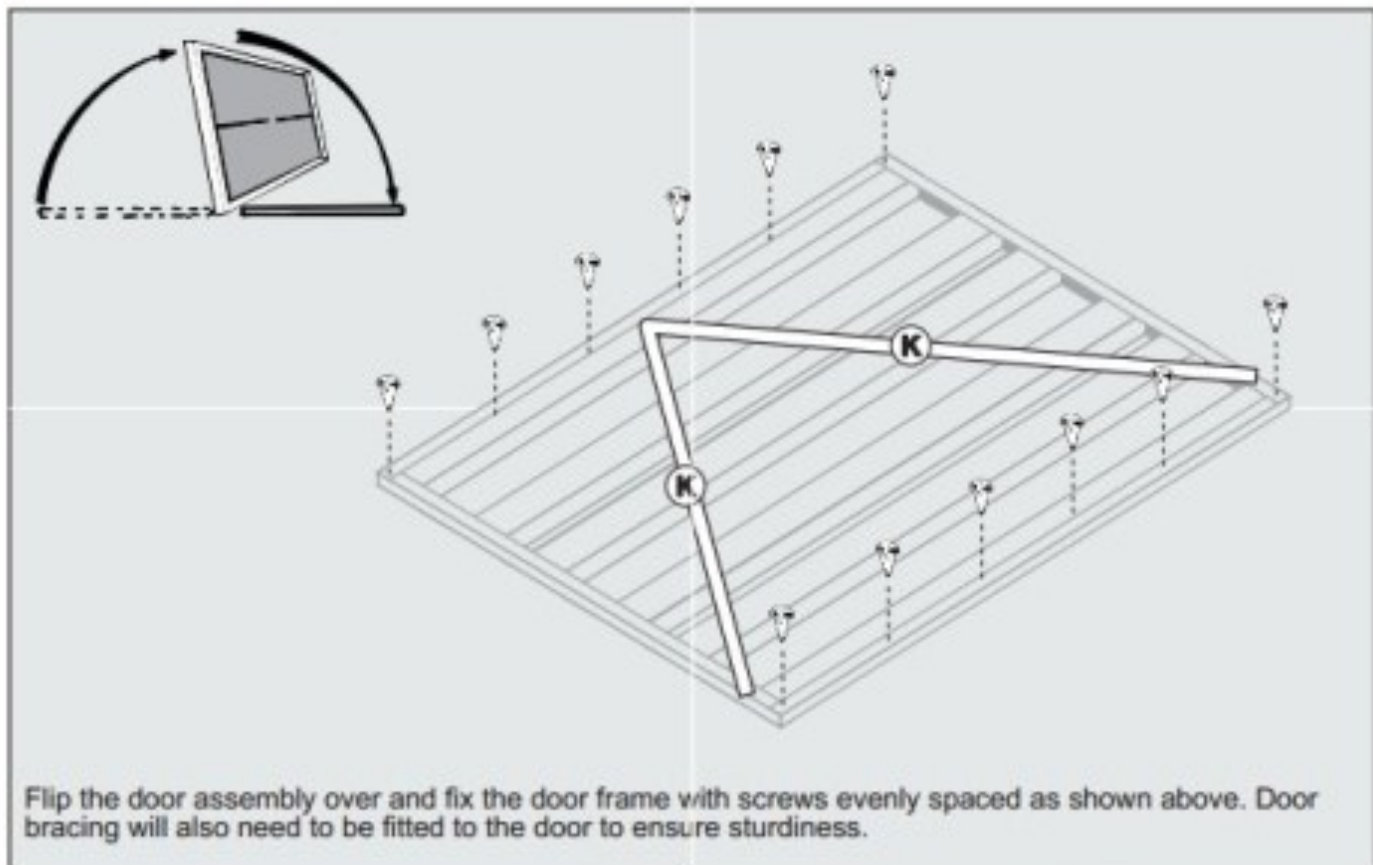

4

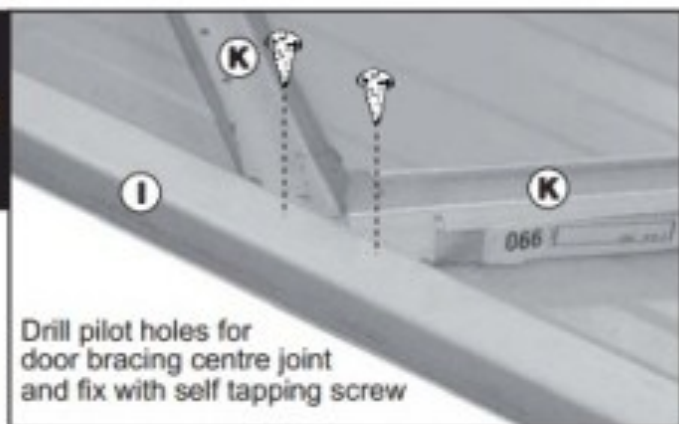

Drill pilot hole for top and bottom bracing joint, and fix with self tapping screw.

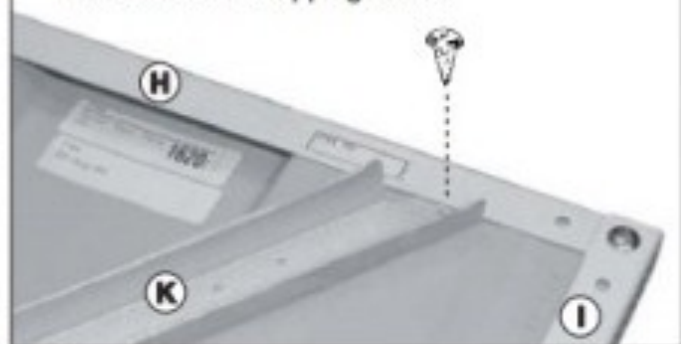

5

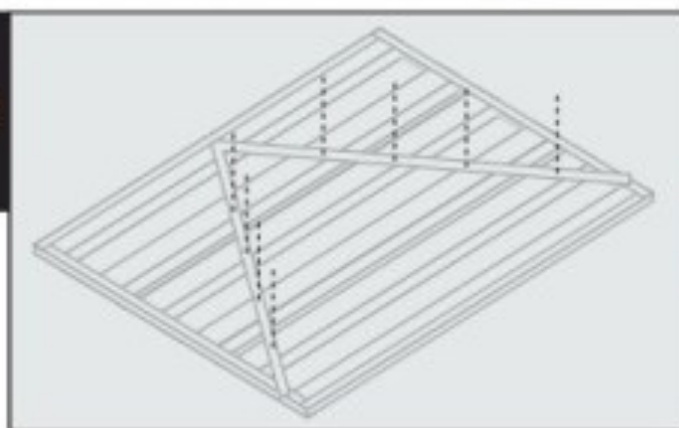

Use the 2.5mm drill bit to drill pilot holes through the door bracing into the door sheeting.

**DO NOT FASTEN BRACING YET**

## ASSEMBLE DOOR

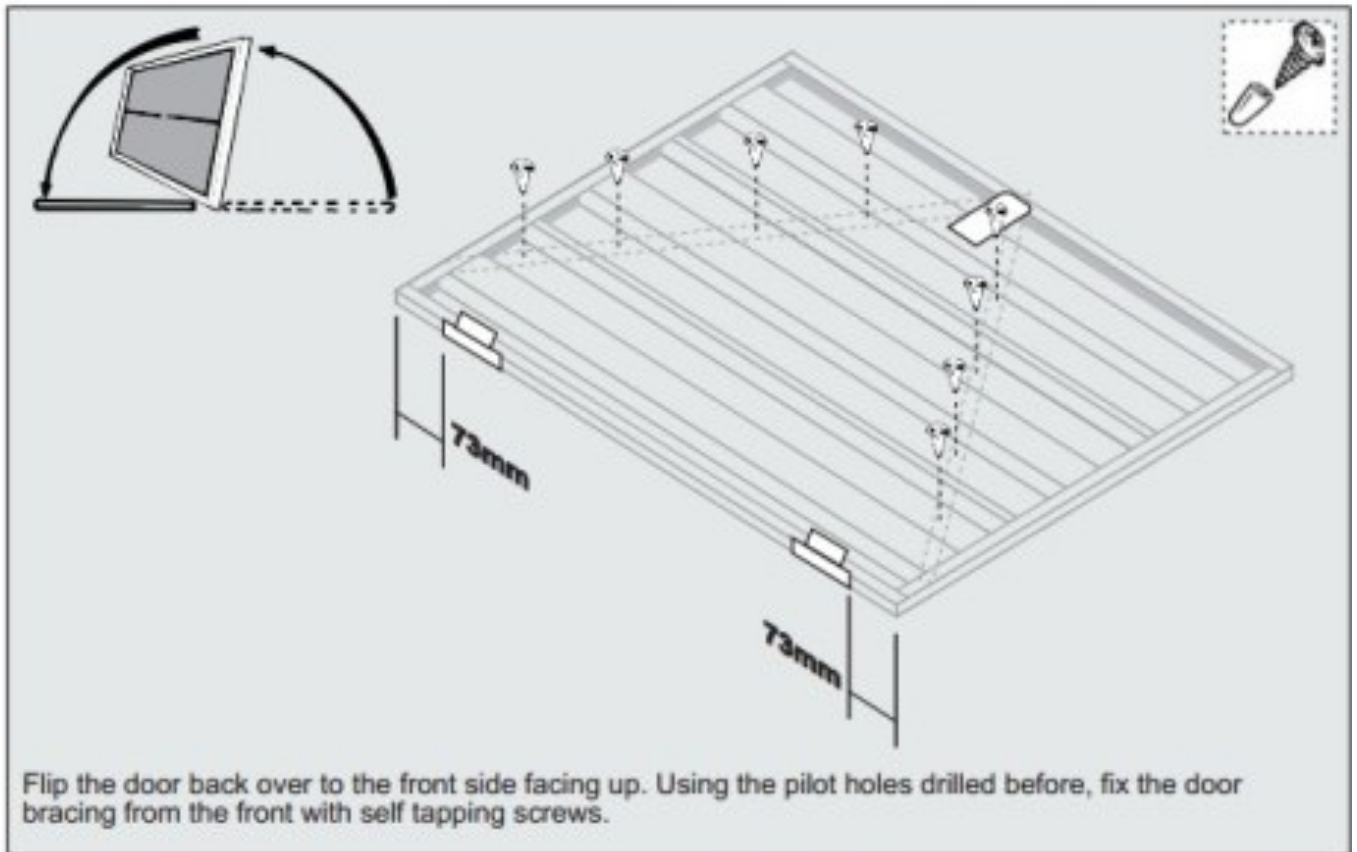

6

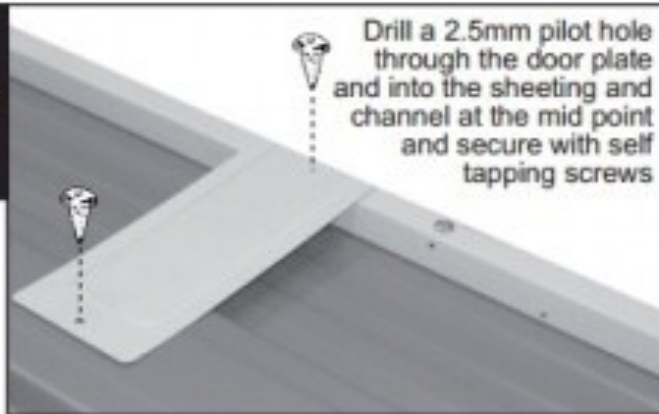

7

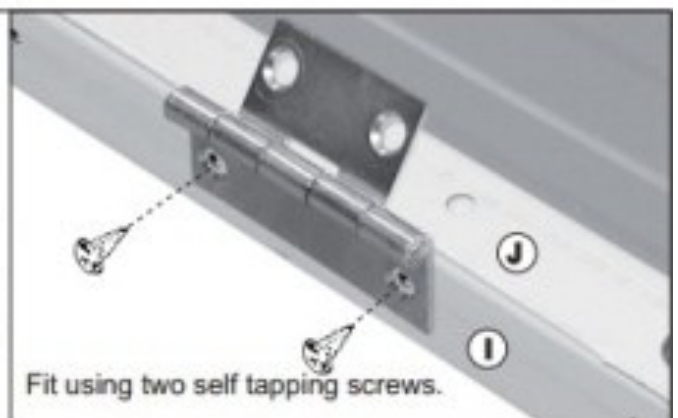
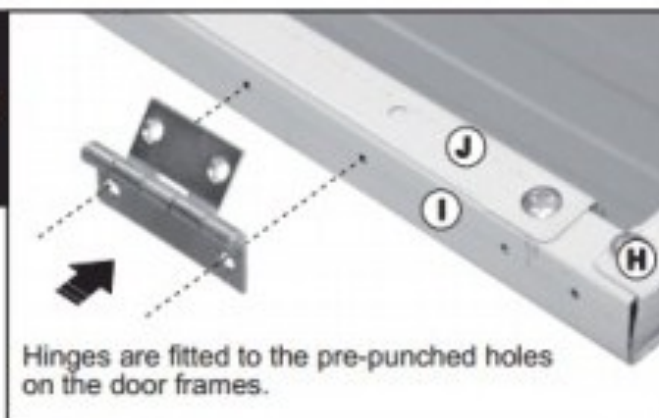

## HANG DOOR

**NOTE:** The diagram below shows a 44 flat roof shed. The assembly process is the same for all sheds.

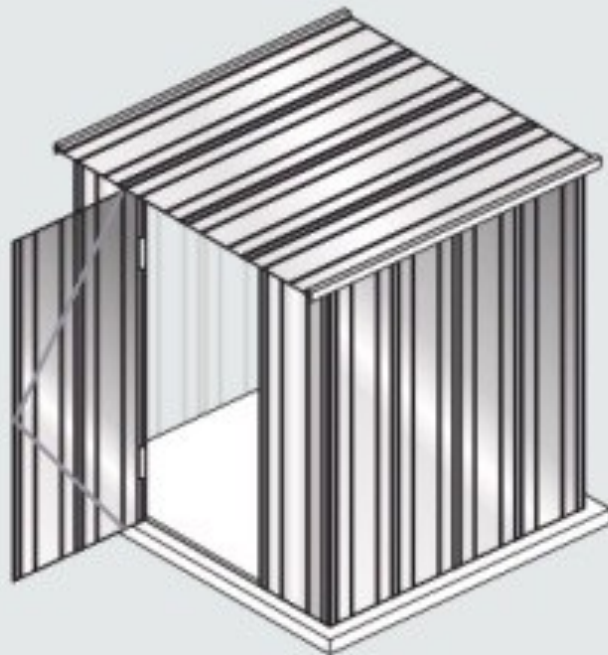

Fit the door to the left or right by fixing the hinges to the pre-drilled holes in the door jambs then fit the padbolt keeper.

1



2



Drill pilot holes to accommodate the padbolt keeper and then fix with self tapping screws

## BOLT DOWN

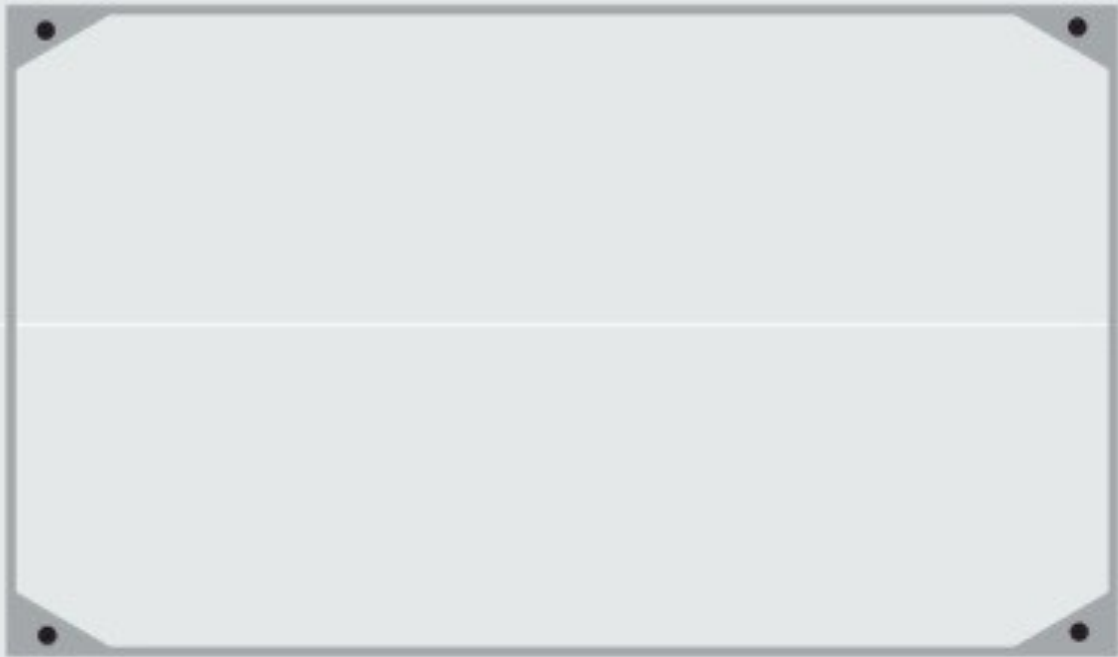

Bolt the shed down through the four corner brackets as shown. Ensure the shed is square.

1

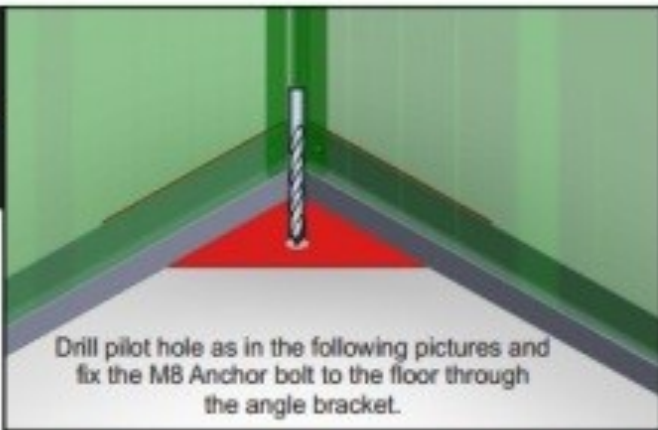

Drill pilot hole as in the following pictures and fix the MB Anchor bolt to the floor through the angle bracket.

50mm



2

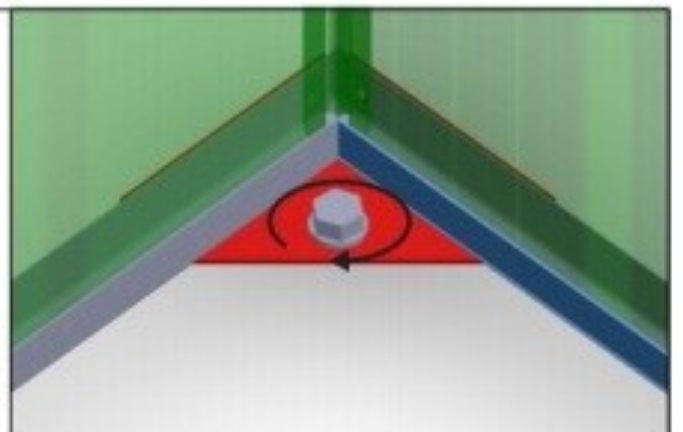
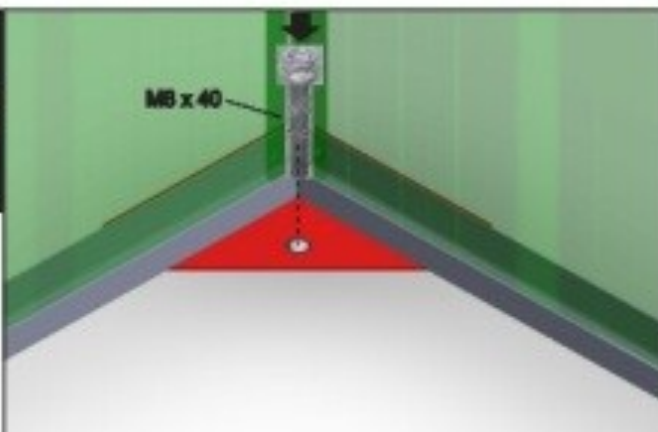

## BOLT DOWN

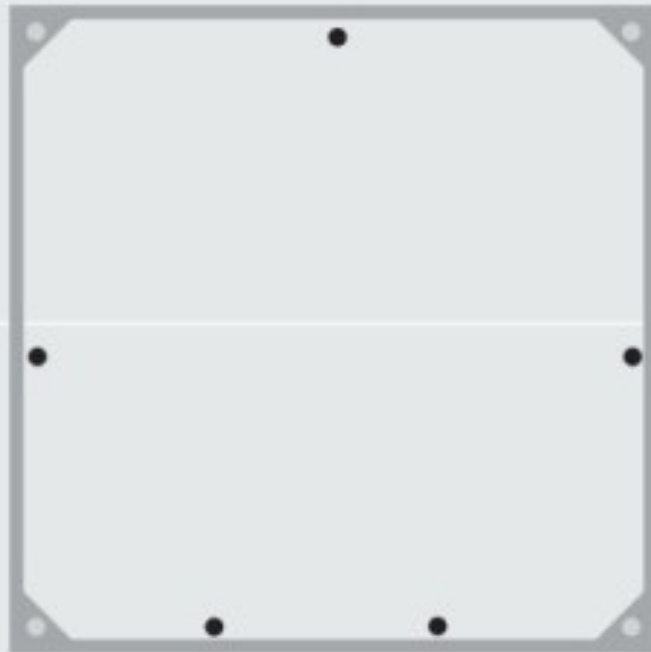

Bolt the shed down through the angle brackets as shown.

1



Drill the hole for the anchor to 50mm depth and then using a 5mm drill bit, drill the holes through the sheeting to attach the bracket to the shed.



2

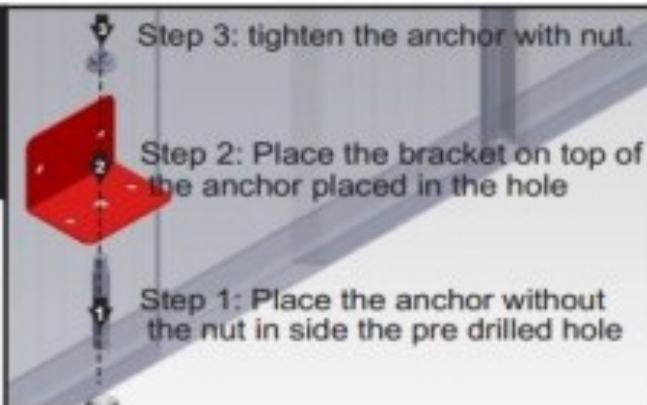

Step 3: tighten the anchor with nut.

Step 2: Place the bracket on top of the anchor placed in the hole

Step 1: Place the anchor without the nut in side the pre drilled hole

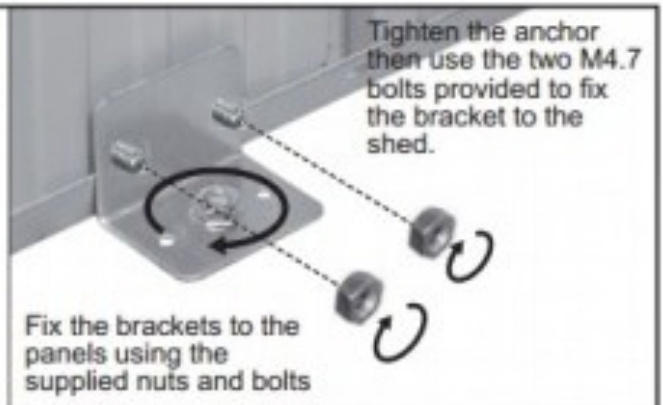

Tighten the anchor then use the two M4.7 bolts provided to fix the bracket to the shed.

Fix the brackets to the panels using the supplied nuts and bolts



## FIT SKYLIGHT (OPTIONAL)

The skylight must be fitted on top of the two adjacent sheets. Fit the steel roof sheets first then fit the skylight as shown below.

1



The skylight is fixed using two (2) screws at the top and bottom of the sheet. The inset shows a closeup of the overlap. Pilot holes will need to be drilled

2

