

FASTTRAK

Simple, Strong, Quick & Easy.

SLIMLINE SIDE ENTRY F36-S

ASSEMBLY INSTRUCTIONS

REVISION 02/15



How to build Video



W2105mm x D1070mm x H1800mm

NOTES

BEFORE COMMENCING SHED ASSEMBLY, CHECK ALL PARTS. IF THERE IS A DISCREPANCY, PLEASE CALL SPANBILT (SEE REAR OF INSTRUCTION BOOK)

DO NOT ASSEMBLE IN WINDY CONDITIONS

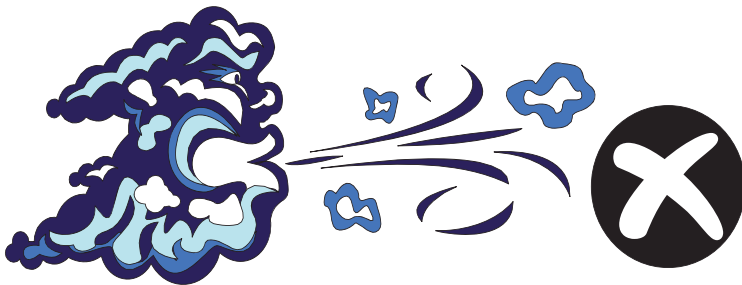

READ INSTRUCTIONS FIRST



2 PERSON ASSEMBLY



THE MANUFACTURERS CANNOT BE HELD RESPONSIBLE FOR ANY CONSEQUENCES DUE TO SHEDS THAT ARE NOT INSTALLED PER INSTRUCTIONS OR FOR DAMAGE DUE TO WEATHER CONDITIONS, ACTS OF GOD OR FOR SHEDS THAT ARE LEFT PARTIALLY ASSEMBLED OVERNIGHT. PARTS MAY CONTAIN SHARP EDGES & CORNERS. CARE MUST BE TAKEN WHEN HANDLING VARIOUS PIECES TO AVOID A MISHAP, FOR SAFETY SAKE, PLEASE USE A PAIR OF WORK GLOVES, EYE PROTECTION & PROTECTIVE CLOTHING WHEN ASSEMBLING OR PERFORMING ANY MAINTENANCE ON THE BUILDING.

TOOLS REQUIRED

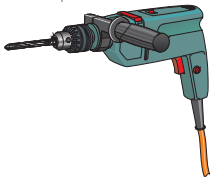

Electric Drill



Cordless Drill

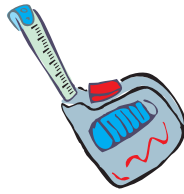

Measuring Tape

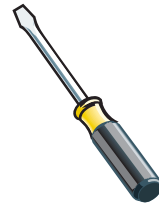

Screwdrivers



8mm Masonry Drill Bit



Shifting Spanner



Builders Pencil



5mm Drill bit



Rubber Mallet



Sturdy Ladder
(two if possible)



Gloves



Protective Eyewear

HANDY HINTS FOR CONSTRUCTION

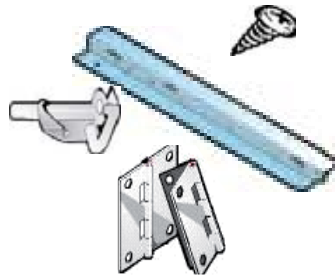

Read instructions and check parts carefully before assembling the shed.

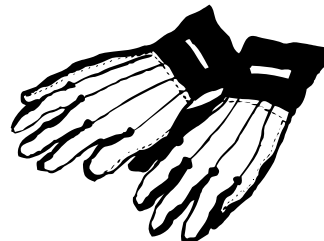

Please wear safety gloves and glasses at all times to protect against sharp metal edges.

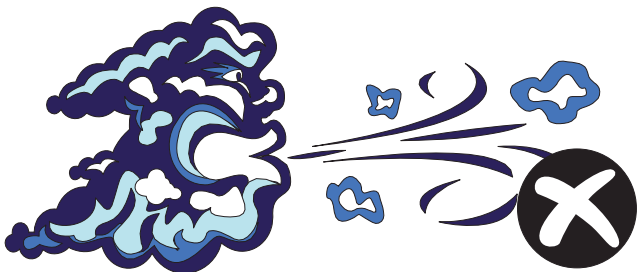

Do not assemble in windy conditions as panels may be difficult to handle and damage may result.

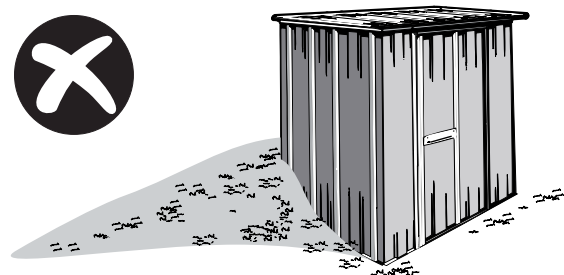



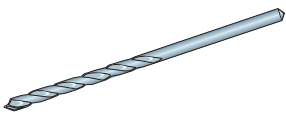





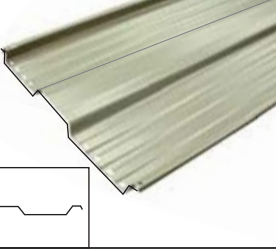
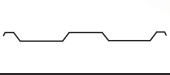

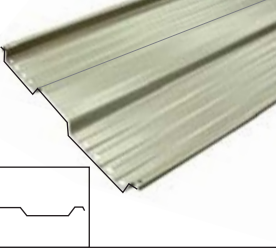
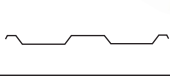

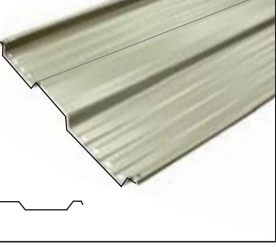
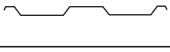

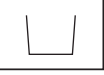
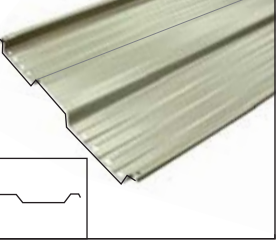
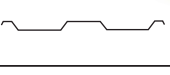
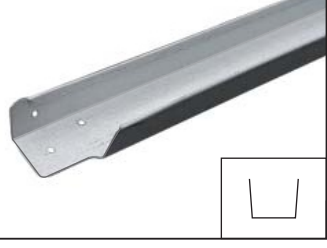
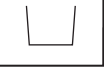
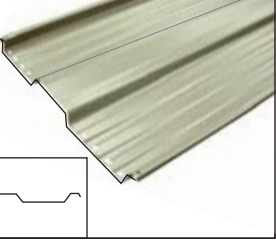
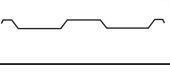
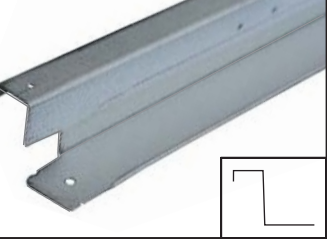
Do not back fill against the shed as this will result in corrosion. Allow drainage from the site.

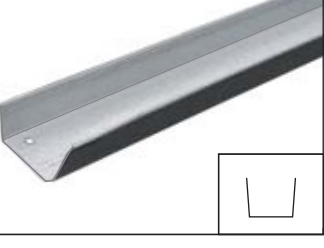
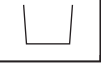

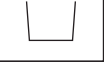
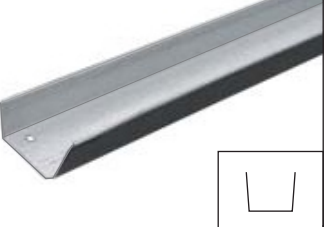







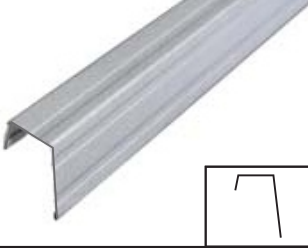

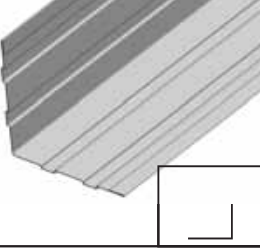

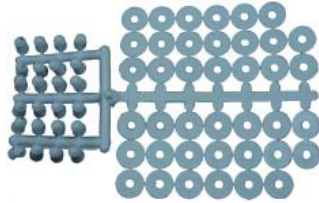
MOST PILOT HOLES ARE PRE-PUNCHED AND IN THIS CASE DRILLING HOLES IS NOT NECESSARY, HOWEVER SOME PILOT HOLES NEED TO BE DRILLED WITH THE INCLUDED 2.5MM DRILL BIT WHERE INDICATED

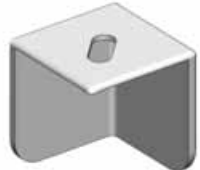
PARTS LIST

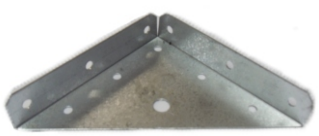
<table border="1"> <tr><td>PRODUCT ID</td><td>C</td></tr> <tr><td>Length</td><td>1800mm</td></tr> <tr><td>Quantity</td><td>12</td></tr> <tr><td colspan="2">Description: Wall Panel</td></tr> </table>  	PRODUCT ID	C	Length	1800mm	Quantity	12	Description: Wall Panel		<table border="1"> <tr><td>PRODUCT ID</td><td>J</td></tr> <tr><td>Length</td><td>1706mm</td></tr> <tr><td>Quantity</td><td>2</td></tr> <tr><td colspan="2">Description: Door Boxing</td></tr> </table>  	PRODUCT ID	J	Length	1706mm	Quantity	2	Description: Door Boxing	
PRODUCT ID	C																
Length	1800mm																
Quantity	12																
Description: Wall Panel																	
PRODUCT ID	J																
Length	1706mm																
Quantity	2																
Description: Door Boxing																	
<table border="1"> <tr><td>PRODUCT ID</td><td>D</td></tr> <tr><td>Length</td><td>1800mm</td></tr> <tr><td>Quantity</td><td>3</td></tr> <tr><td colspan="2">Description: Wall Corner Panel</td></tr> </table>  	PRODUCT ID	D	Length	1800mm	Quantity	3	Description: Wall Corner Panel		<table border="1"> <tr><td>PRODUCT ID</td><td>K</td></tr> <tr><td>Length</td><td>1280mm</td></tr> <tr><td>Quantity</td><td>2</td></tr> <tr><td colspan="2">Description: Door Bracing</td></tr> </table>  	PRODUCT ID	K	Length	1280mm	Quantity	2	Description: Door Bracing	
PRODUCT ID	D																
Length	1800mm																
Quantity	3																
Description: Wall Corner Panel																	
PRODUCT ID	K																
Length	1280mm																
Quantity	2																
Description: Door Bracing																	
<table border="1"> <tr><td>PRODUCT ID</td><td>E</td></tr> <tr><td>Length</td><td>1149mm</td></tr> <tr><td>Quantity</td><td>6</td></tr> <tr><td colspan="2">Description: Roof Panel</td></tr> </table>  	PRODUCT ID	E	Length	1149mm	Quantity	6	Description: Roof Panel		<table border="1"> <tr><td>PRODUCT ID</td><td>M</td></tr> <tr><td>Length</td><td>2099mm</td></tr> <tr><td>Quantity</td><td>4</td></tr> <tr><td colspan="2">Description: Top/Bottom Front/Rear Channel</td></tr> </table>  	PRODUCT ID	M	Length	2099mm	Quantity	4	Description: Top/Bottom Front/Rear Channel	
PRODUCT ID	E																
Length	1149mm																
Quantity	6																
Description: Roof Panel																	
PRODUCT ID	M																
Length	2099mm																
Quantity	4																
Description: Top/Bottom Front/Rear Channel																	
<table border="1"> <tr><td>PRODUCT ID</td><td>F</td></tr> <tr><td>Length</td><td>1738mm</td></tr> <tr><td>Quantity</td><td>2</td></tr> <tr><td colspan="2">Description: Door Panel Side (partially slit)</td></tr> </table>  	PRODUCT ID	F	Length	1738mm	Quantity	2	Description: Door Panel Side (partially slit)		<table border="1"> <tr><td>PRODUCT ID</td><td>N</td></tr> <tr><td>Length</td><td>1061mm</td></tr> <tr><td>Quantity</td><td>4</td></tr> <tr><td colspan="2">Description: Side Channel Top/Bottom</td></tr> </table>  	PRODUCT ID	N	Length	1061mm	Quantity	4	Description: Side Channel Top/Bottom	
PRODUCT ID	F																
Length	1738mm																
Quantity	2																
Description: Door Panel Side (partially slit)																	
PRODUCT ID	N																
Length	1061mm																
Quantity	4																
Description: Side Channel Top/Bottom																	
<table border="1"> <tr><td>PRODUCT ID</td><td>G</td></tr> <tr><td>Length</td><td>1738mm</td></tr> <tr><td>Quantity</td><td>1</td></tr> <tr><td colspan="2">Description: Door Panel Centre</td></tr> </table>  	PRODUCT ID	G	Length	1738mm	Quantity	1	Description: Door Panel Centre		<table border="1"> <tr><td>PRODUCT ID</td><td>Q</td></tr> <tr><td>Length</td><td>1800mm</td></tr> <tr><td>Quantity</td><td>2</td></tr> <tr><td colspan="2">Description: Door Jamb</td></tr> </table>  	PRODUCT ID	Q	Length	1800mm	Quantity	2	Description: Door Jamb	
PRODUCT ID	G																
Length	1738mm																
Quantity	1																
Description: Door Panel Centre																	
PRODUCT ID	Q																
Length	1800mm																
Quantity	2																
Description: Door Jamb																	
<table border="1"> <tr><td>PRODUCT ID</td><td>H</td></tr> <tr><td>Length</td><td>1008mm</td></tr> <tr><td>Quantity</td><td>2</td></tr> <tr><td colspan="2">Description: Door Frame Top/Bottom</td></tr> </table>  	PRODUCT ID	H	Length	1008mm	Quantity	2	Description: Door Frame Top/Bottom		<table border="1"> <tr><td>PRODUCT ID</td><td>R</td></tr> <tr><td>Length</td><td>1021mm</td></tr> <tr><td>Quantity</td><td>1</td></tr> <tr><td colspan="2">Description: Bottom Door Spacer</td></tr> </table>  	PRODUCT ID	R	Length	1021mm	Quantity	1	Description: Bottom Door Spacer	
PRODUCT ID	H																
Length	1008mm																
Quantity	2																
Description: Door Frame Top/Bottom																	
PRODUCT ID	R																
Length	1021mm																
Quantity	1																
Description: Bottom Door Spacer																	
<table border="1"> <tr><td>PRODUCT ID</td><td>I</td></tr> <tr><td>Length</td><td>1742mm</td></tr> <tr><td>Quantity</td><td>2</td></tr> <tr><td colspan="2">Description: Door Frame Side</td></tr> </table>  	PRODUCT ID	I	Length	1742mm	Quantity	2	Description: Door Frame Side		<table border="1"> <tr><td>PRODUCT ID</td><td>S</td></tr> <tr><td>Length</td><td>1021mm</td></tr> <tr><td>Quantity</td><td>1</td></tr> <tr><td colspan="2">Description: Top Door Spacer</td></tr> </table>  	PRODUCT ID	S	Length	1021mm	Quantity	1	Description: Top Door Spacer	
PRODUCT ID	I																
Length	1742mm																
Quantity	2																
Description: Door Frame Side																	
PRODUCT ID	S																
Length	1021mm																
Quantity	1																
Description: Top Door Spacer																	

PARTS LIST

<table border="1"> <tr> <td>PRODUCT ID</td> <td>W</td> </tr> <tr> <td>Length</td> <td>1141mm</td> </tr> <tr> <td>Quantity</td> <td>2</td> </tr> <tr> <td colspan="2">Description: Roof Angle Trim</td> </tr> </table>	PRODUCT ID	W	Length	1141mm	Quantity	2	Description: Roof Angle Trim			<table border="1"> <tr> <td>Quantity</td> <td>1 each</td> </tr> <tr> <td colspan="2">Description: Padbolt & Keeper</td> </tr> </table>	Quantity	1 each	Description: Padbolt & Keeper		
PRODUCT ID	W														
Length	1141mm														
Quantity	2														
Description: Roof Angle Trim															
Quantity	1 each														
Description: Padbolt & Keeper															
<table border="1"> <tr> <td>PRODUCT ID</td> <td>V</td> </tr> <tr> <td>Length</td> <td>2096mm</td> </tr> <tr> <td>Quantity</td> <td>2</td> </tr> <tr> <td colspan="2">Description: Gutter Trim</td> </tr> </table>	PRODUCT ID	V	Length	2096mm	Quantity	2	Description: Gutter Trim			<table border="1"> <tr> <td>Quantity</td> <td>1 each</td> </tr> <tr> <td colspan="2">Description: Phillips Head Bit & 2.5mm Drill Bit</td> </tr> </table>	Quantity	1 each	Description: Phillips Head Bit & 2.5mm Drill Bit		
PRODUCT ID	V														
Length	2096mm														
Quantity	2														
Description: Gutter Trim															
Quantity	1 each														
Description: Phillips Head Bit & 2.5mm Drill Bit															
<table border="1"> <tr> <td>PRODUCT ID</td> <td>Y</td> </tr> <tr> <td>Length</td> <td>1800mm</td> </tr> <tr> <td>Quantity</td> <td>2</td> </tr> <tr> <td colspan="2">Description: End Channel</td> </tr> </table>	PRODUCT ID	Y	Length	1800mm	Quantity	2	Description: End Channel			<table border="1"> <tr> <td>Quantity</td> <td>1</td> </tr> <tr> <td colspan="2">Description: Plastic Washer and Screw Cap Sheet</td> </tr> </table>	Quantity	1	Description: Plastic Washer and Screw Cap Sheet		
PRODUCT ID	Y														
Length	1800mm														
Quantity	2														
Description: End Channel															
Quantity	1														
Description: Plastic Washer and Screw Cap Sheet															
<table border="1"> <tr> <td>Quantity</td> <td>2</td> </tr> <tr> <td colspan="2">Description: Hinges (offset)</td> </tr> </table>	Quantity	2	Description: Hinges (offset)			<table border="1"> <tr> <td>Quantity</td> <td>4</td> </tr> <tr> <td colspan="2">Description: Plastic Corner Cap</td> </tr> </table>	Quantity	4	Description: Plastic Corner Cap						
Quantity	2														
Description: Hinges (offset)															
Quantity	4														
Description: Plastic Corner Cap															
<table border="1"> <tr> <td>Quantity</td> <td>200</td> </tr> <tr> <td colspan="2">Description: Self Tapping Screws - Silver</td> </tr> </table>	Quantity	200	Description: Self Tapping Screws - Silver			<table border="1"> <tr> <td>Quantity</td> <td>4</td> </tr> <tr> <td colspan="2">Description: Corner Bracket</td> </tr> </table>	Quantity	4	Description: Corner Bracket						
Quantity	200														
Description: Self Tapping Screws - Silver															
Quantity	4														
Description: Corner Bracket															
<table border="1"> <tr> <td>Quantity</td> <td>2</td> </tr> <tr> <td colspan="2">Description: Clip Nut</td> </tr> </table>	Quantity	2	Description: Clip Nut			<table border="1"> <tr> <td>Quantity</td> <td>7</td> </tr> <tr> <td colspan="2">Description: Masonry Anchor</td> </tr> </table>	Quantity	7	Description: Masonry Anchor						
Quantity	2														
Description: Clip Nut															
Quantity	7														
Description: Masonry Anchor															
<table border="1"> <tr> <td>Quantity</td> <td>1</td> </tr> <tr> <td colspan="2">Description: Door Plate</td> </tr> </table>	Quantity	1	Description: Door Plate			<table border="1"> <tr> <td>Description:</td> <td>Quantity</td> </tr> <tr> <td>55mm Bracket</td> <td>3</td> </tr> <tr> <td>3/16" Nut & Bolt</td> <td>6</td> </tr> </table>	Description:	Quantity	55mm Bracket	3	3/16" Nut & Bolt	6			
Quantity	1														
Description: Door Plate															
Description:	Quantity														
55mm Bracket	3														
3/16" Nut & Bolt	6														

FOUNDATION

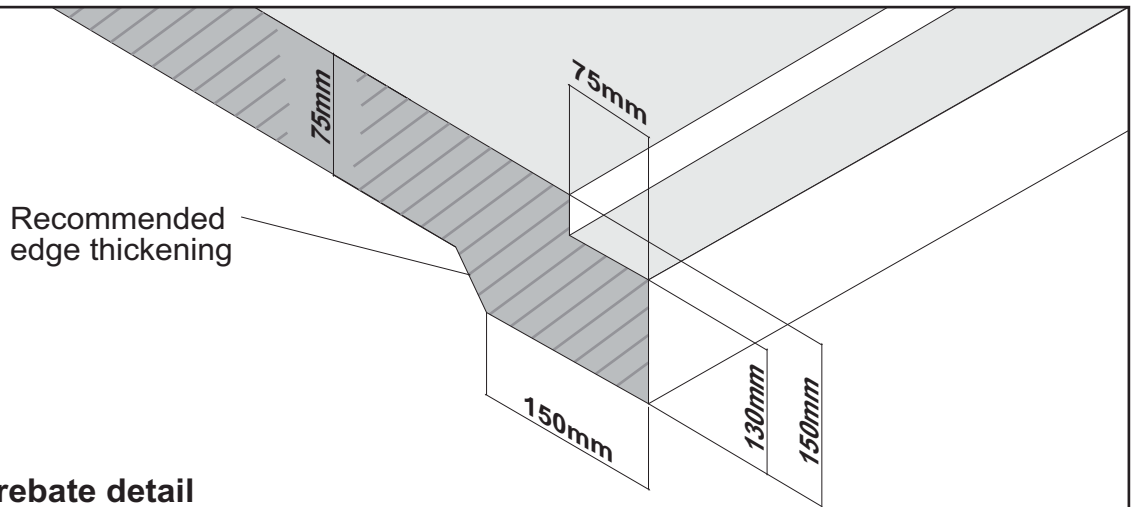

Recommended slab rebate detail

Although *not required*, it is strongly recommended that, to avoid water leakage around the base of your shed, a rebate be cast into the slab. This will allow the shed to sit below the slab level and prevent water from reaching the upper level of the slab.

If you planning a rebated slab make sure to cut the 4 corners at $125 \times 45^\circ$ as shown in detail below.

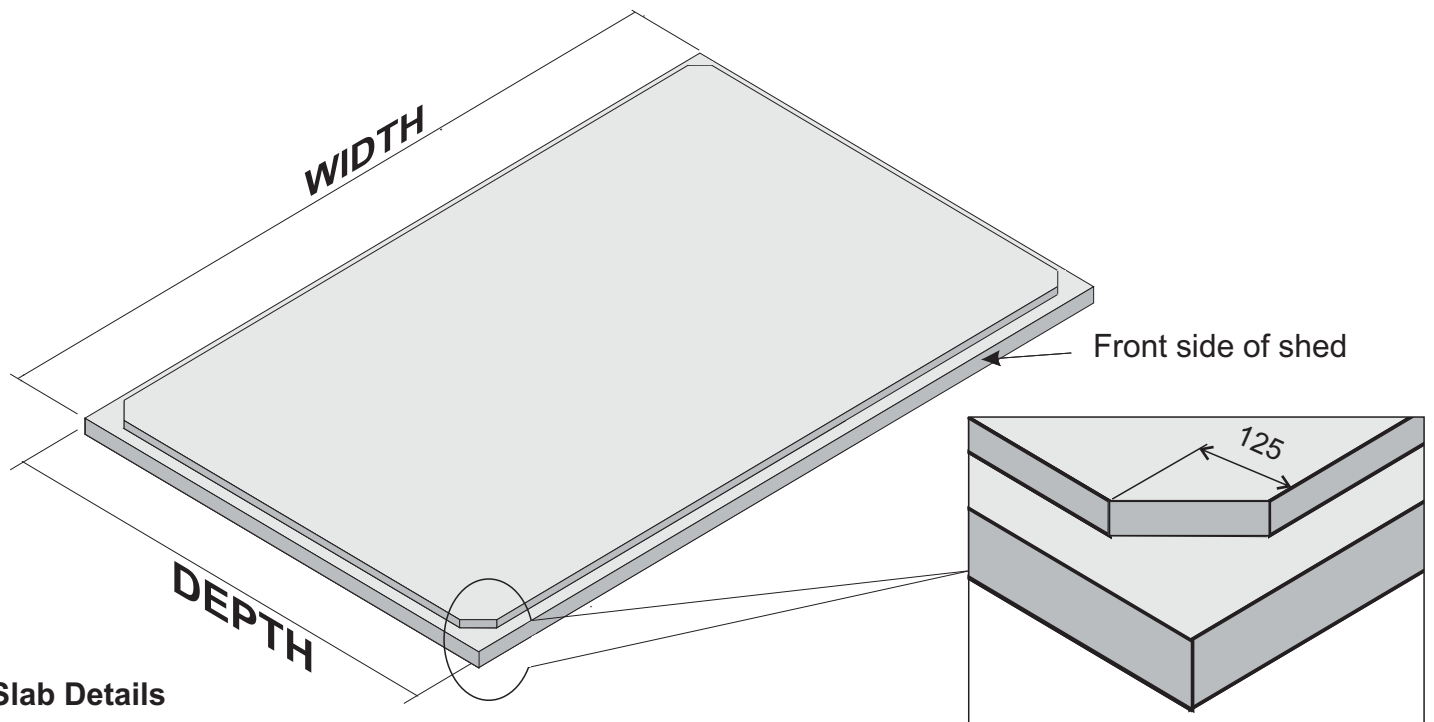

Slab Details

Your garden shed must be erected on a solid, level and square foundation. We strongly recommend you pour a concrete slab 75mm thick, reinforced with SL62 mesh (minimum) using dimensions from the table below.

Masonry anchors are supplied

SHED CODE	OUTER SLAB SIZE width x depth	ANCHORS M8 x 40mm
SLSE-36	1170mmx2205mm	7

REAR WALL PANEL (2 REQUIRED)

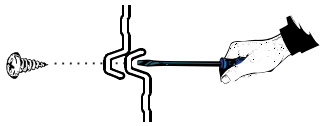

If you are having trouble screwing the channel to the sheets, chock behind the hole .

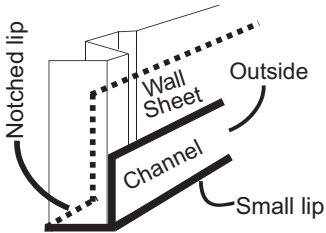

Ensure that the small lip of the channel is to the outside of the shed. Notched big lip is to inside

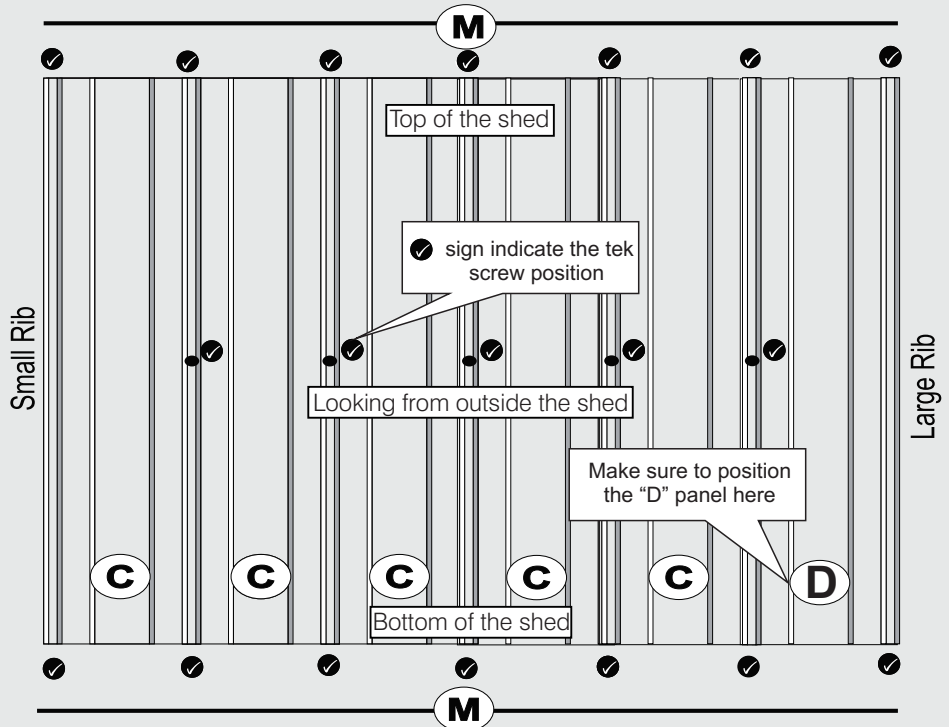

Fit the top and bottom channel to the wall panels. Ensure the large rib on the sheets are positioned as per the diagram above.
NB: Some channel holes may not align perfectly when the sheets are laid out. They can be easily manipulated into position and screw to the channel.

1

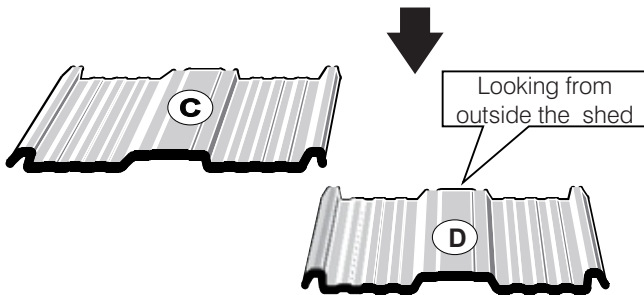

Lay the wall panels out with the large rib overlapping the small.

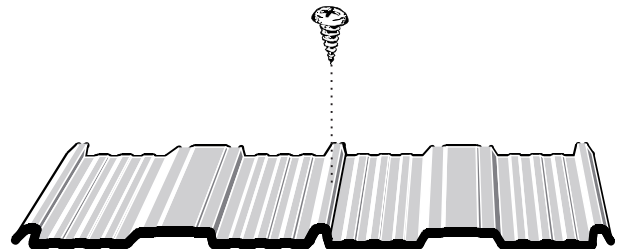

Screw the wall panels in the centre of the rib as shown.

2

Notched ends are orientated to the outer edges of the panel

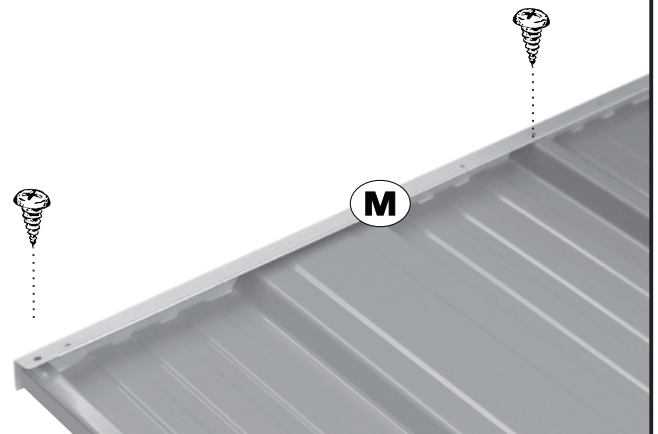
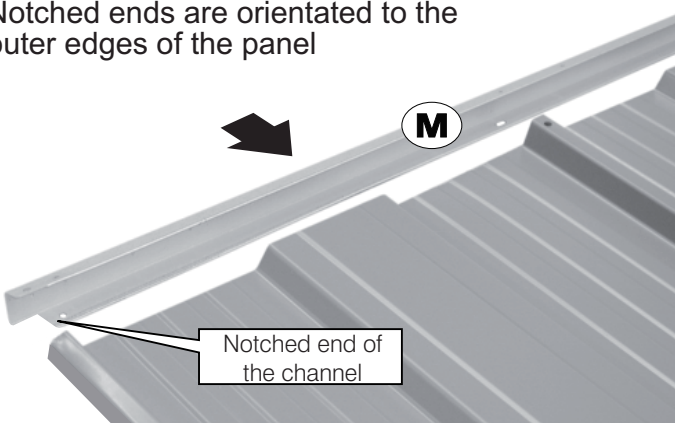

REAR WALL PANEL

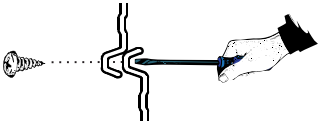

If you are having trouble screwing the channel to the sheets, chock behind the hole .

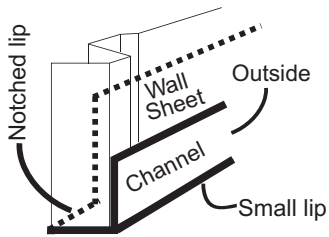

Ensure that the small lip of the channel is to the outside of the shed. Notched big lip is to inside

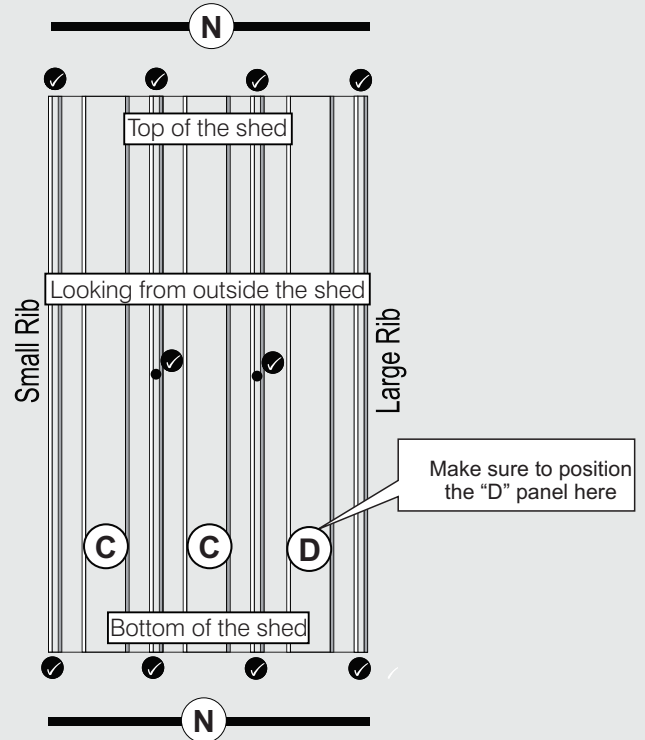

Fit the top and bottom channel to the wall panels. Ensure the channel is flush with the edge of the sheets.
NB: Some channel holes may not align perfectly when the sheets are laid out. They can be easily manipulated into position and screw to the channel.

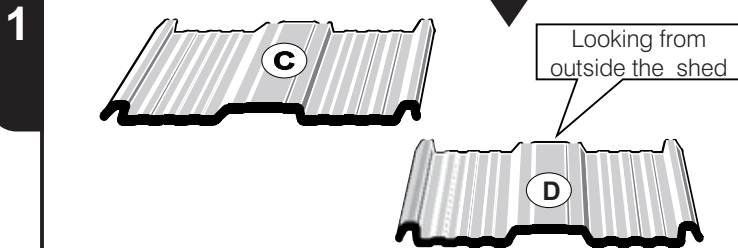

Lay the wall panels out with the large rib overlapping the small.

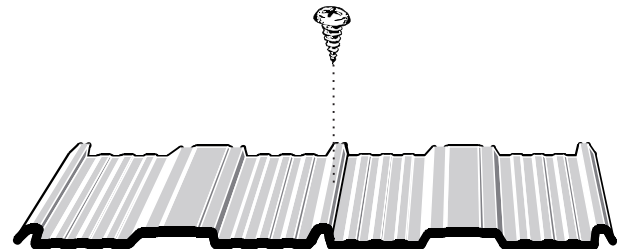

Screw the wall panels in the centre of the rib as shown.

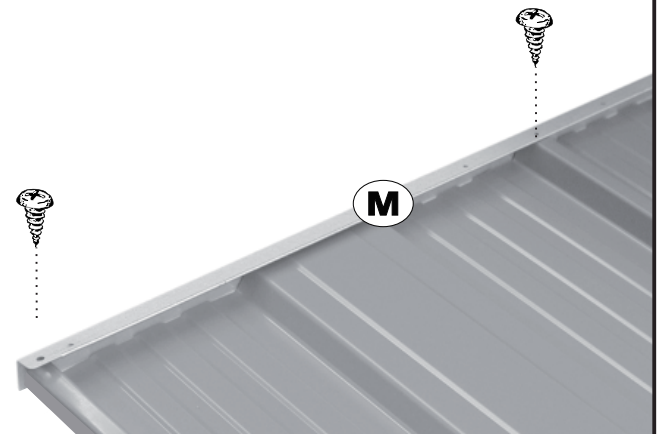
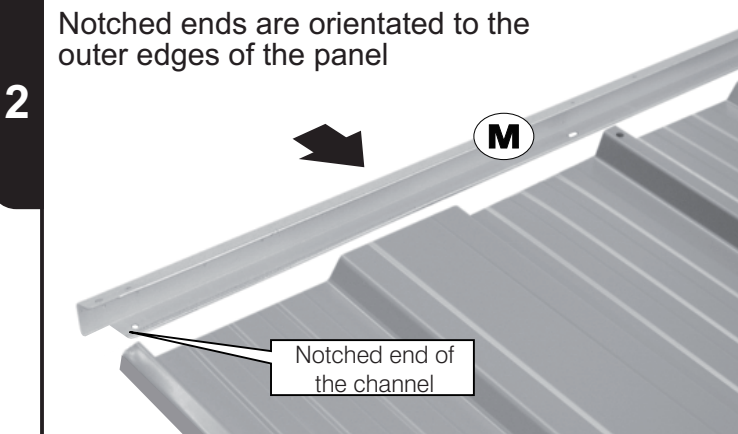

STAND AND JOIN WALL PANELS

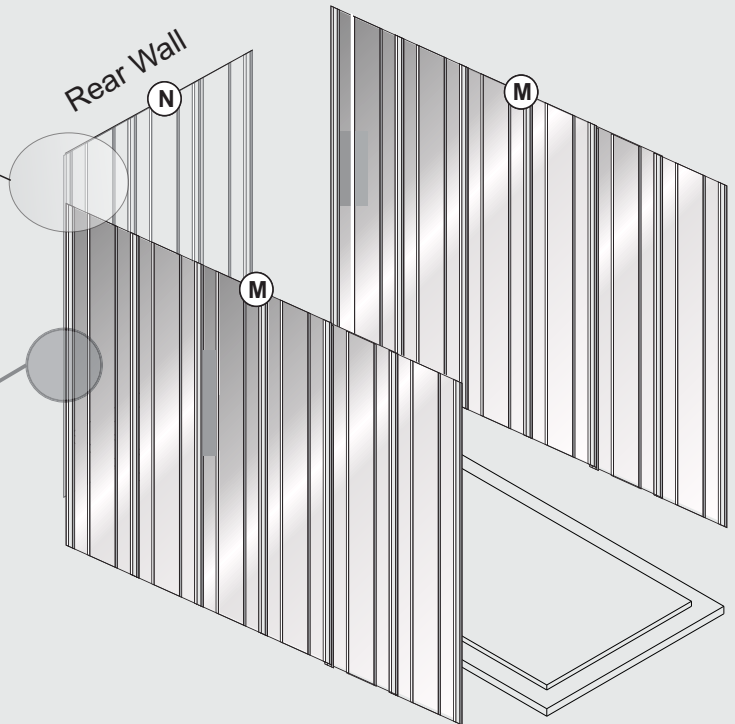
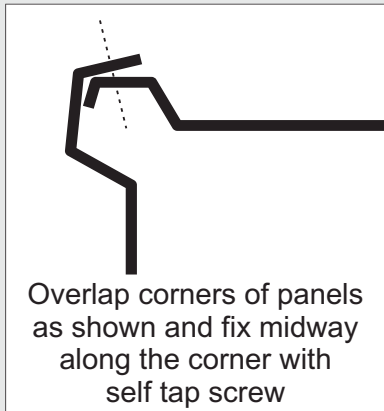
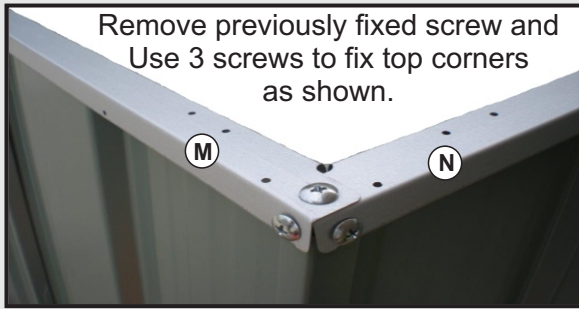

Once the three wall panels are assembled, they can now be stood and fixed together. Fix using the corner brackets and screws as shown below. N.B when assembling large wall models, eg. 7 panels width and above, extra care should be taken, with person two providing adequate support to stop the wall from distorting.

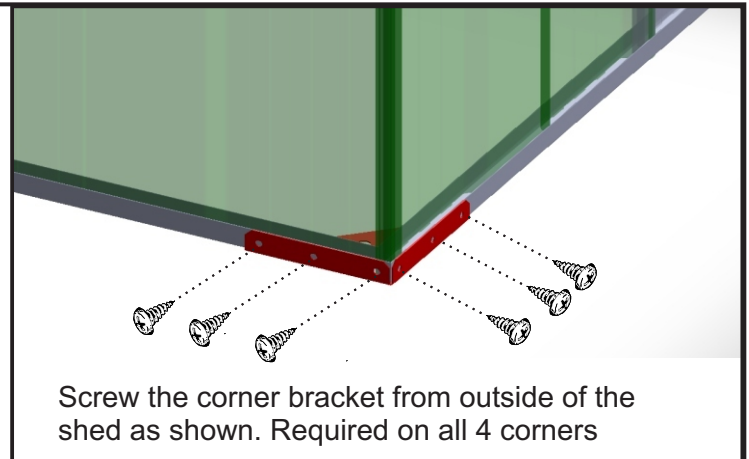
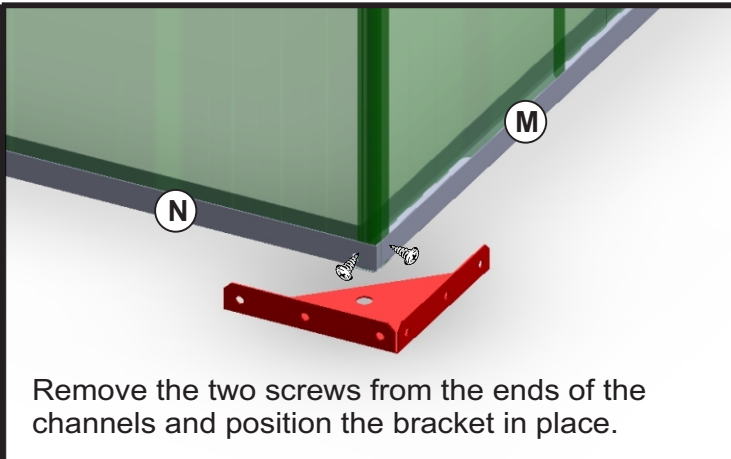

FIXING END CHANNELS

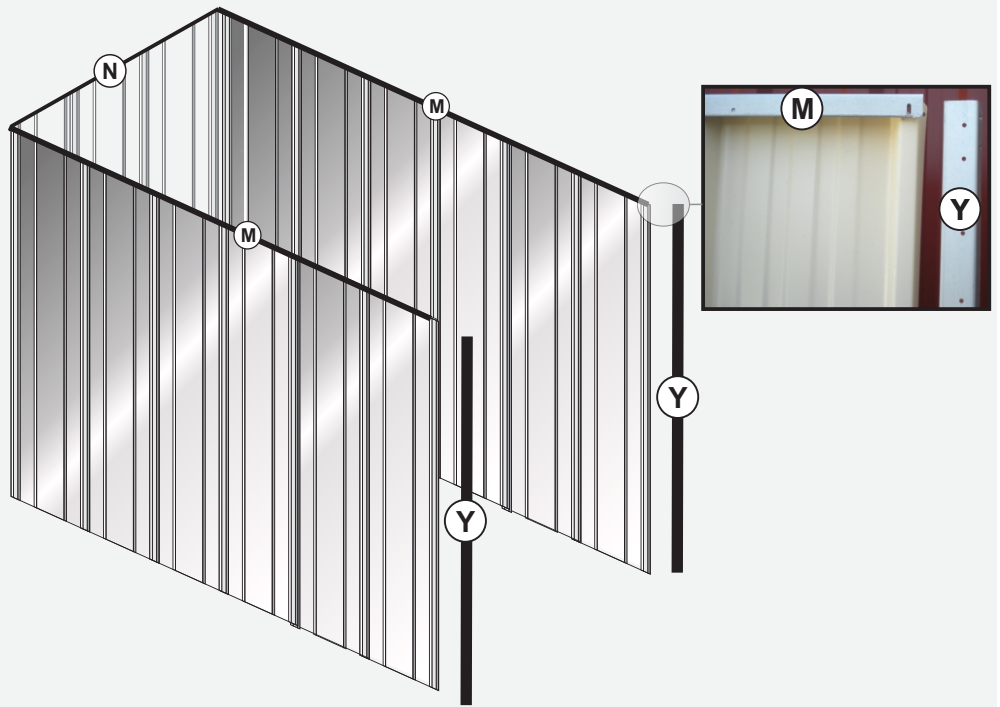

Once the (rear) top and bottom joints are completed its time to place End channel "Y" to both sides

Top view, Channel "M" removed for clarity

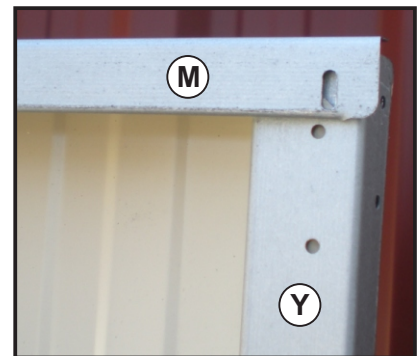
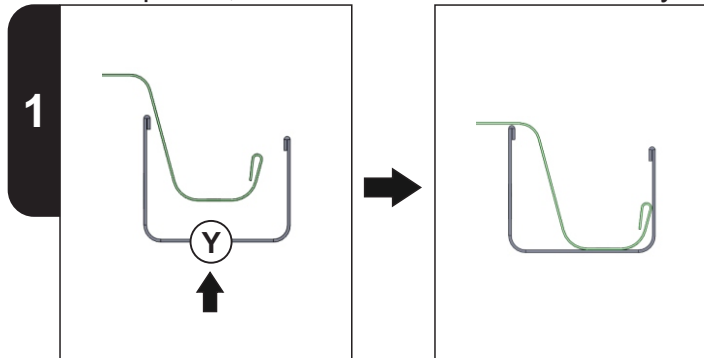

FIXING END CHANNELS

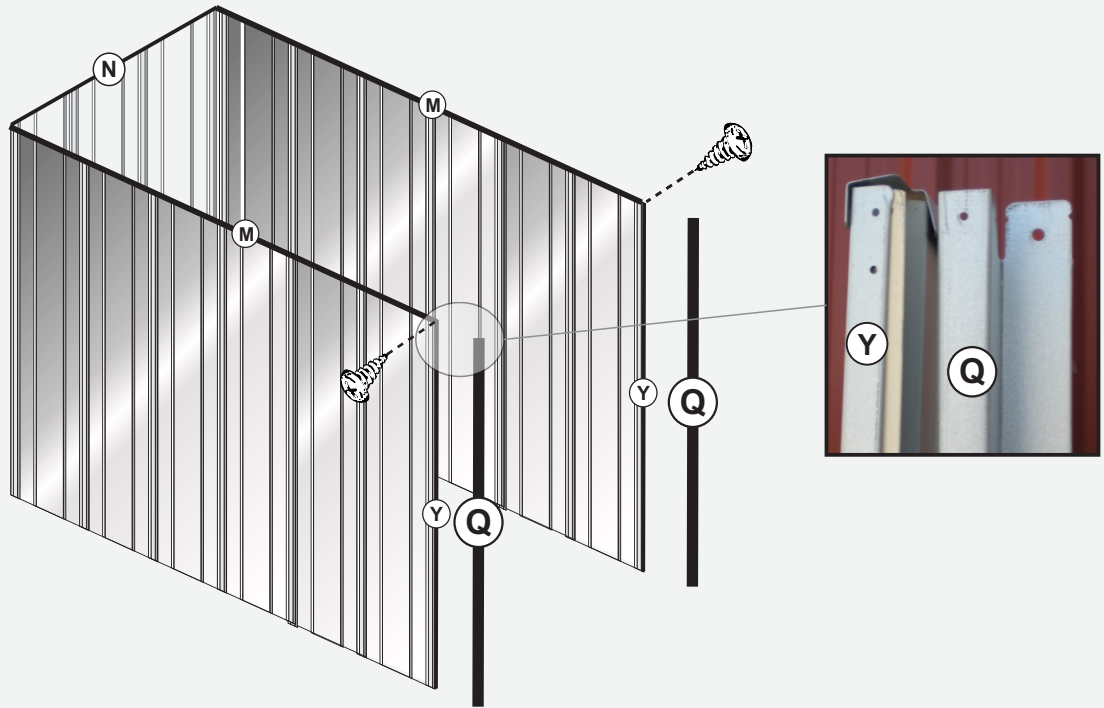

Place door jamb "Q" to the End channel "Y" on both side as shown.
Then screw at top on both sides

Top view, Channel "M" removed for clarity

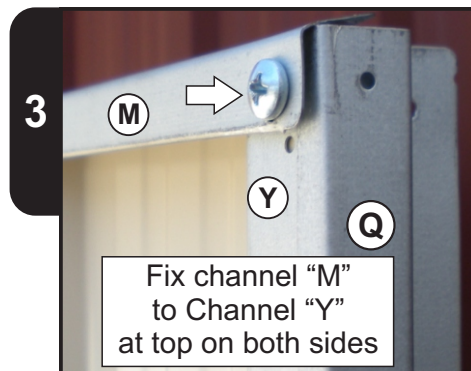
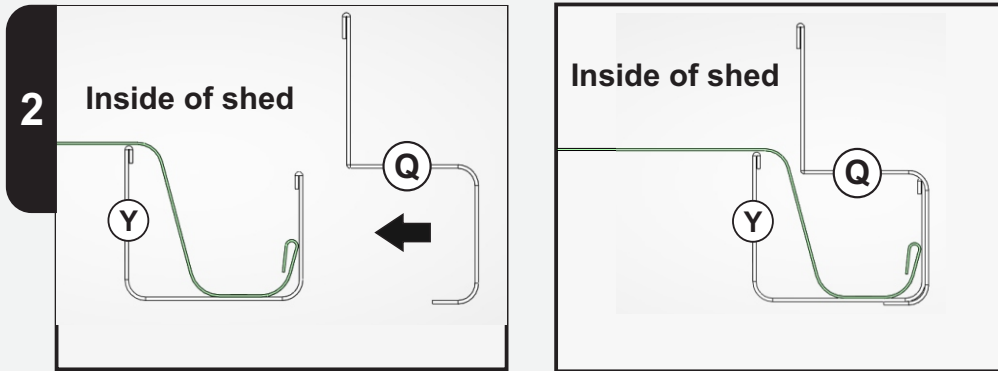

FIXING END CHANNELS

Fix side channel "N" to the top and bottom as shown.

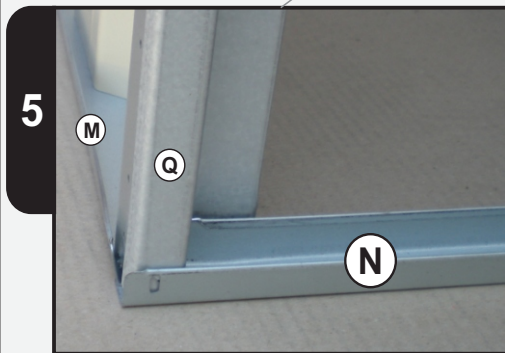
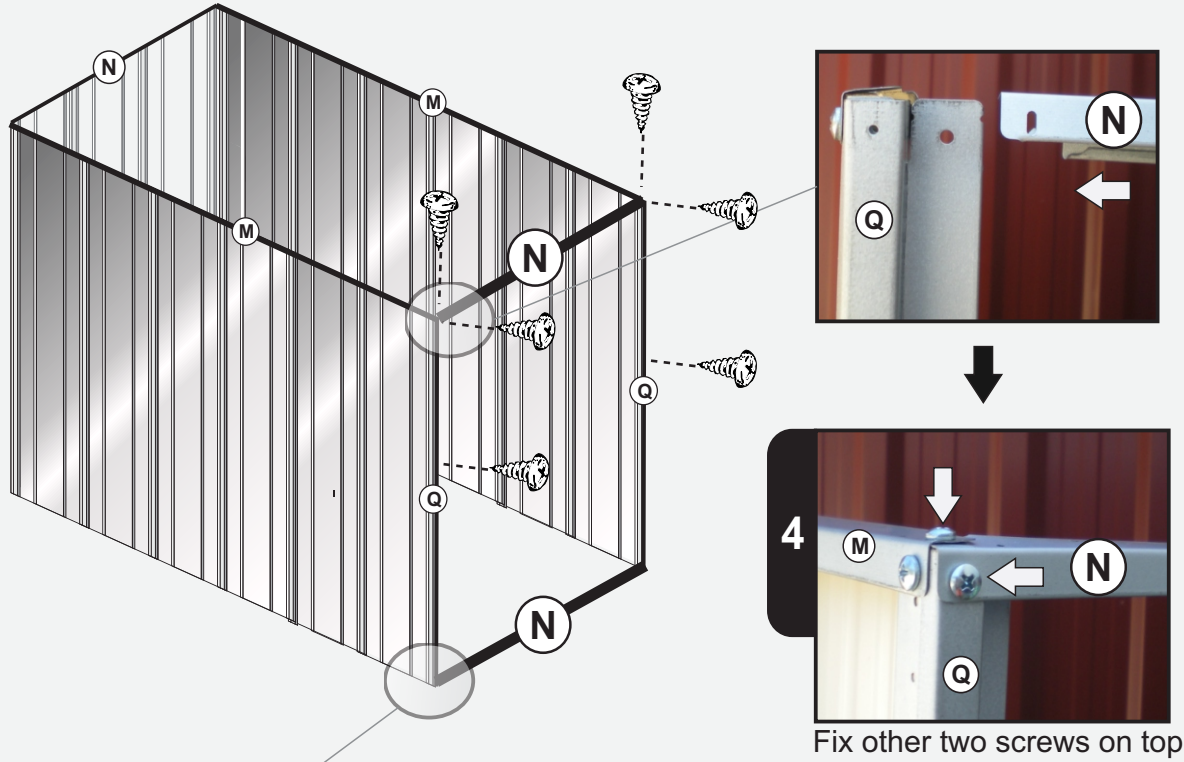

Place the Bottom channel "N"

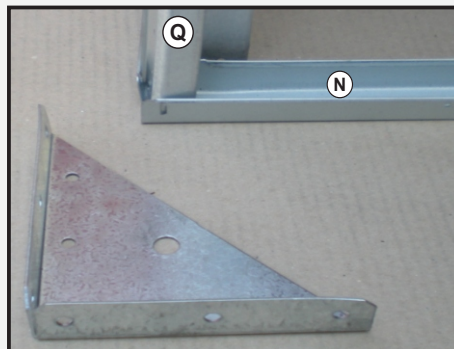

Place the Corner Bracket

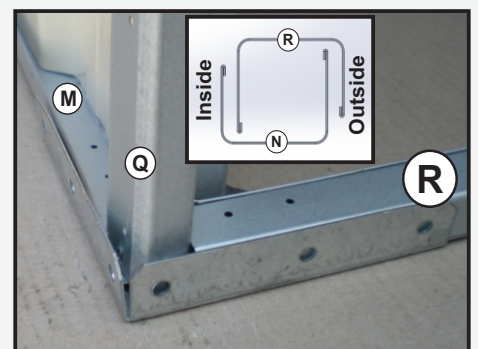

Slide the Corner Bracket and position the Boxing channel "R".

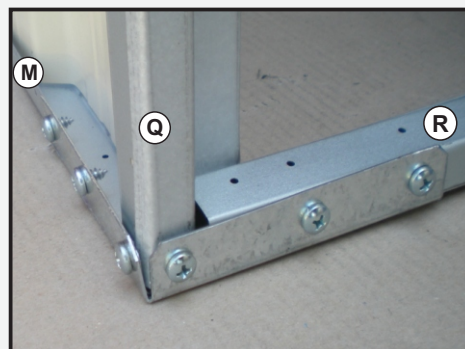

Screw the Corner Bracket to the channel use 6 tek screws to fix

FIXING DOOR CHANNELS

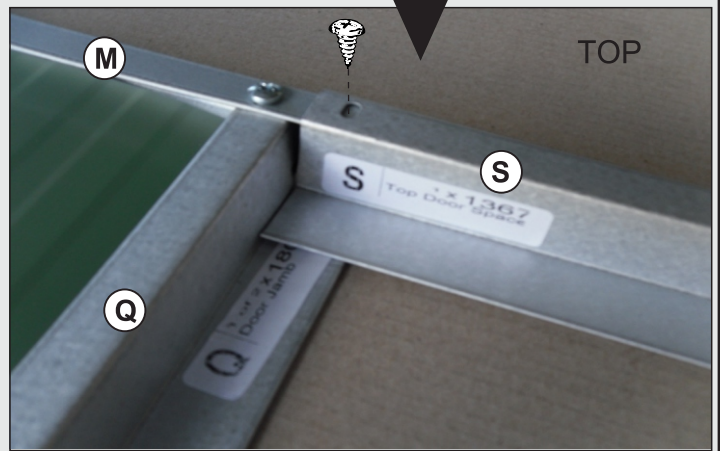
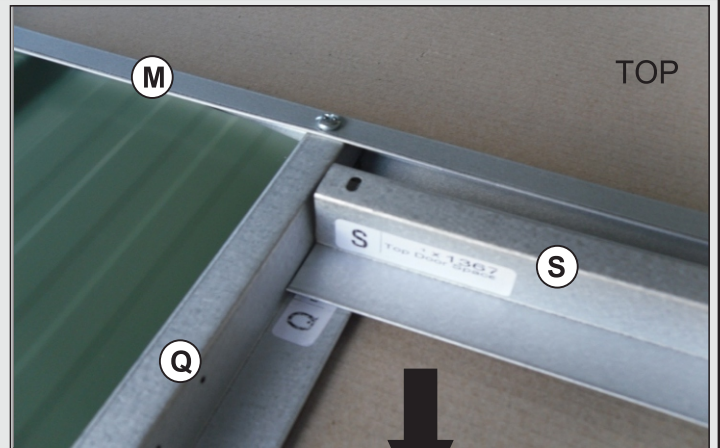
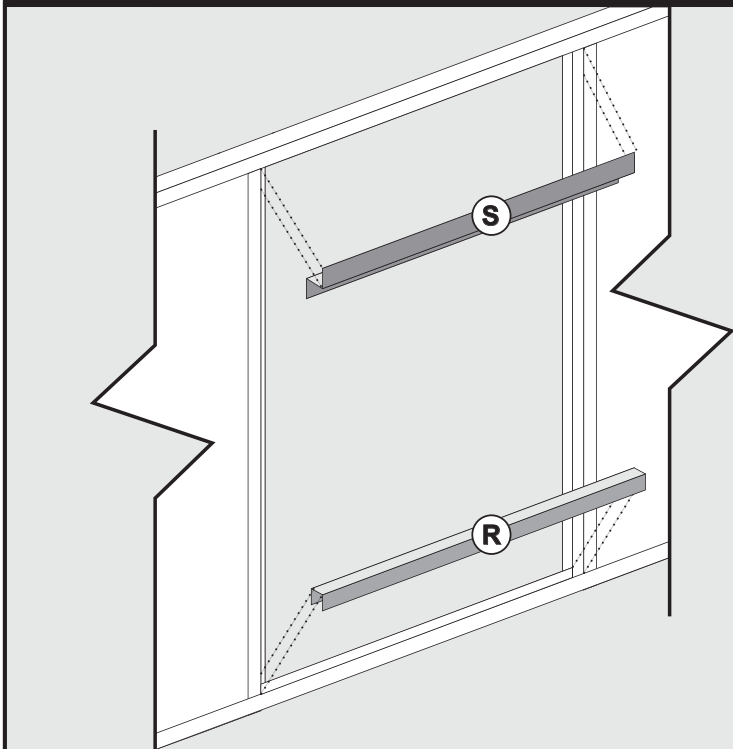

*** Diagram shown for a different model shed but procedure is similar

Fit the top door spacer "S" to the front wall panel as shown. Some pilot holes may need to be drilled with the included 2.5mm drill bit

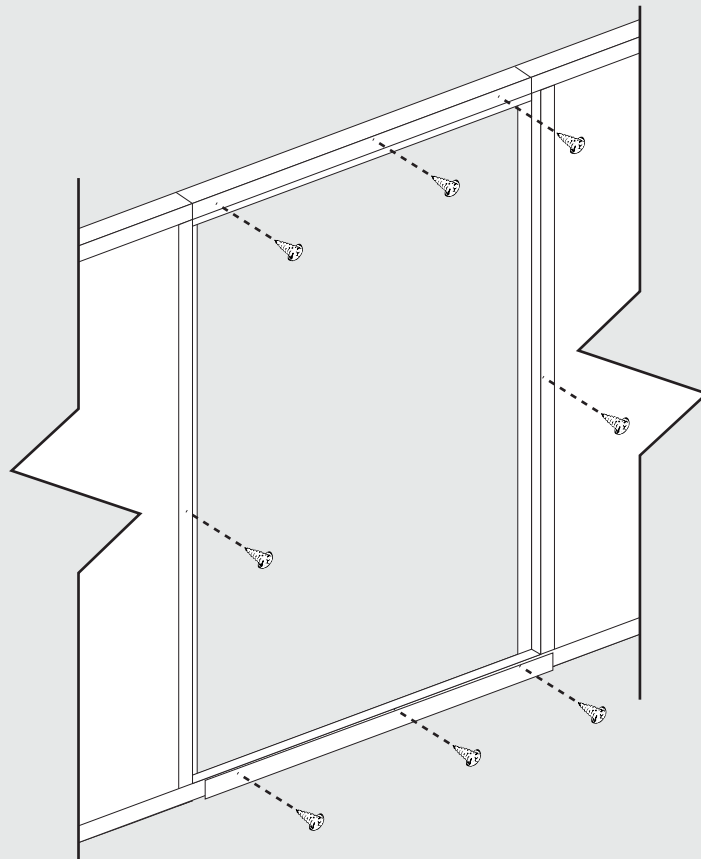

FIT ROOF

1



Step 1: Place roof sheet on top, start from the left, big rib should flush with channel "N"
Place all sheets as shown.

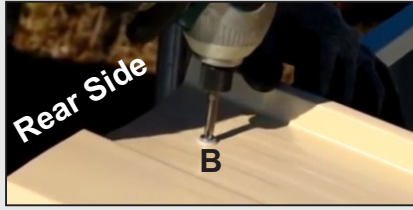

Step 2: Start from rear side.
Screw all holes "B"
Do not screw the hole "A" yet.



Step 3: Screw the front side through all holes "C".
one screw per sheet.



Step 4: Screw the Rear side holes "A". You may either pre drill or use self drilling tek screw to fix this.

Two screw holes should be positioned on the rear side of the shed



Fit plastic washers to roof screws

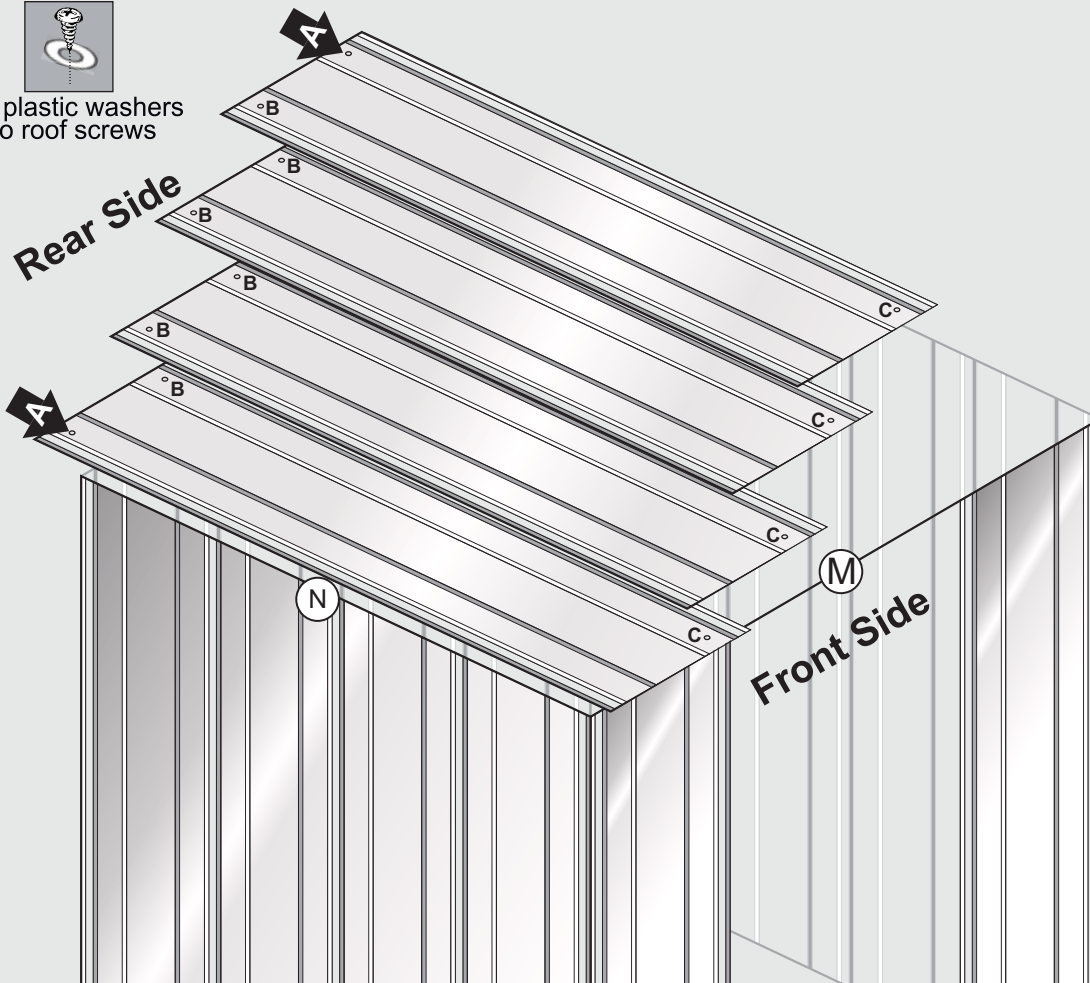

FIT ROOF TRIMS

2

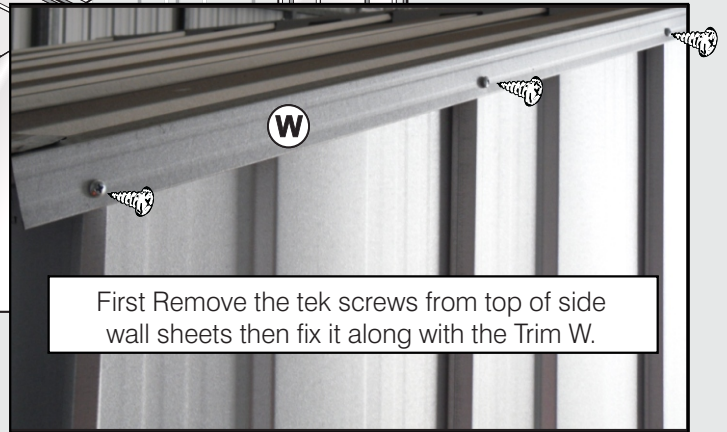
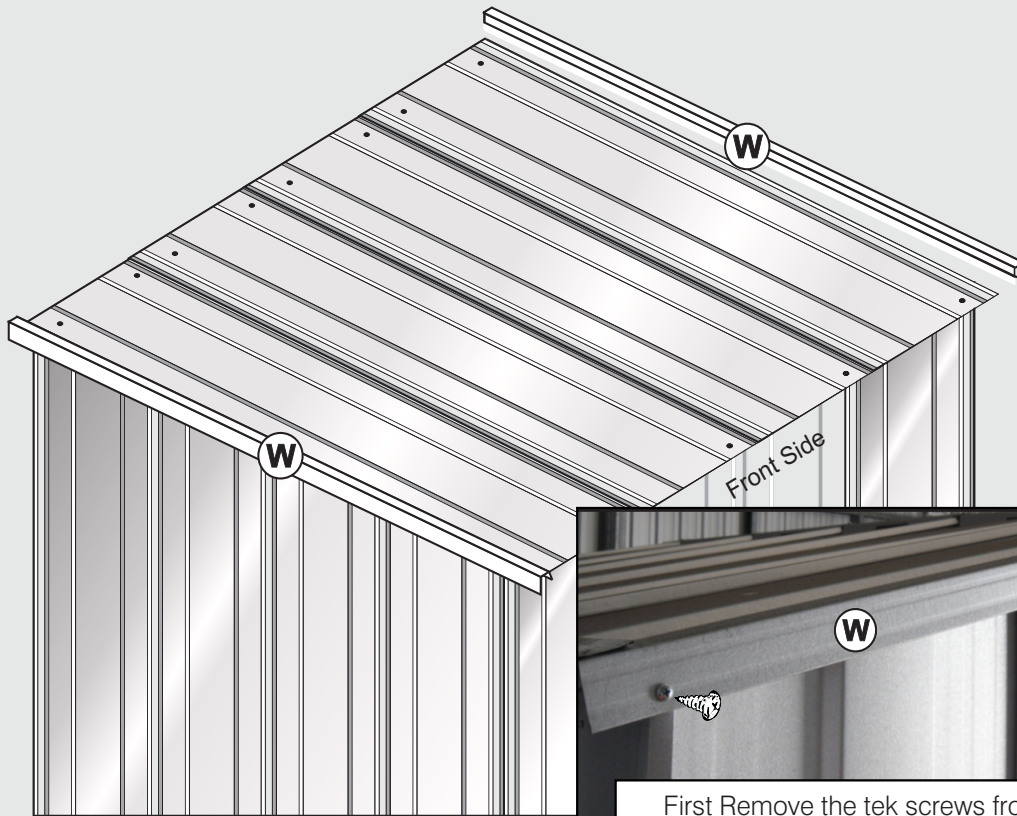

First Remove the tek screws from top of side wall sheets then fix it along with the Trim W.

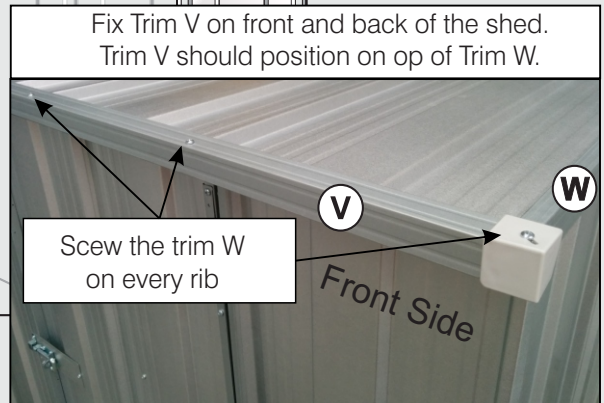
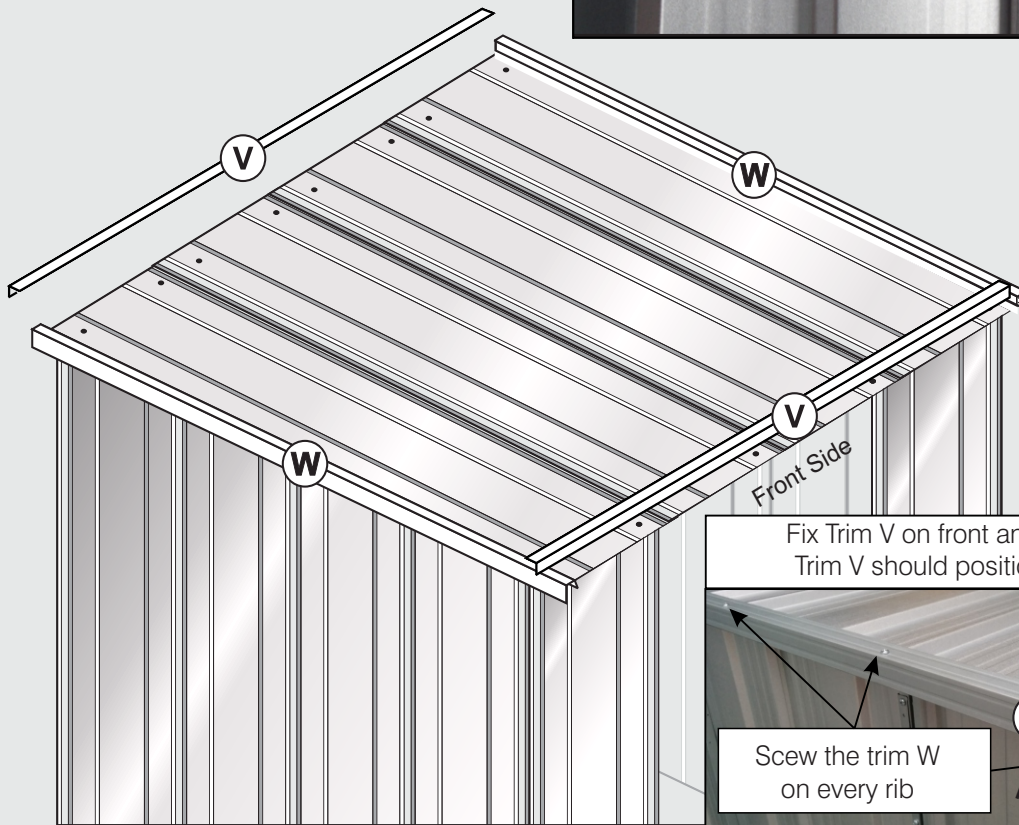

Fix Trim V on front and back of the shed. Trim V should position on top of Trim W.

Scew the trim W on every rib

ASSEMBLE DOOR

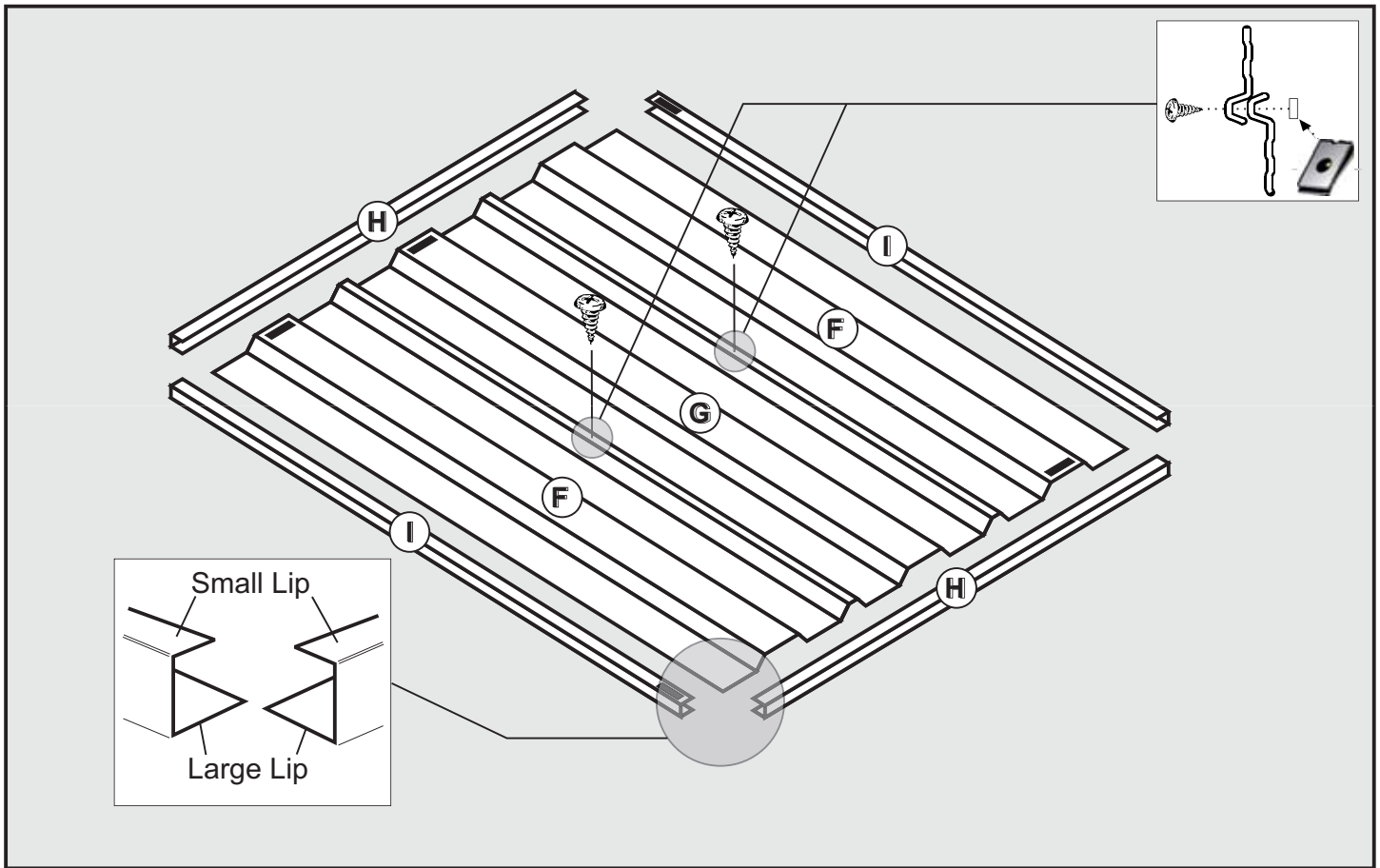

1

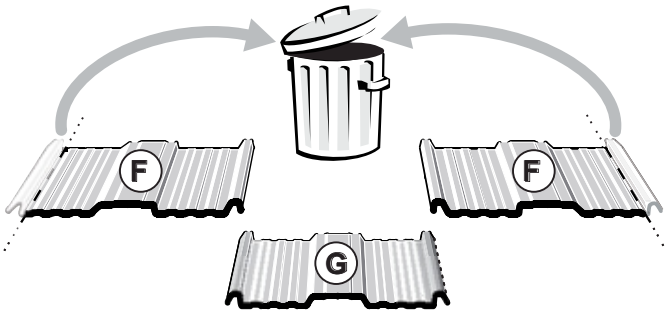

Two of the door sheets come with one rib partially slit. Break them off and discard them.

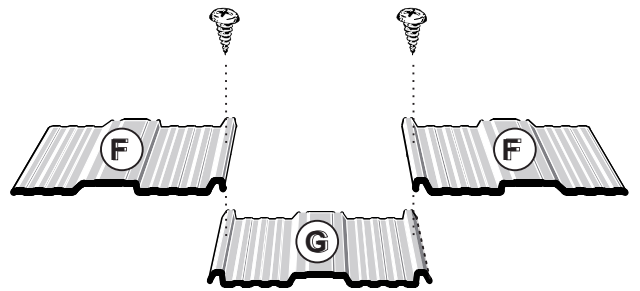

Screw the sheets in the centre.

2

Frames slide under the sheet as shown. Ensure the small lip of the frame is to the top.

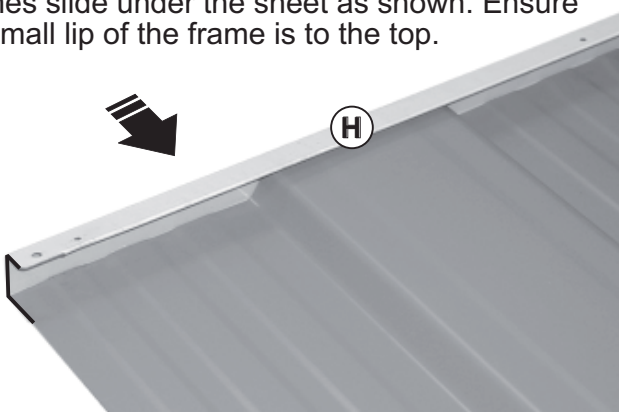

Fix door frames with a screw in each corner. Ensure that the big hole sits over the small.



ASSEMBLE DOOR

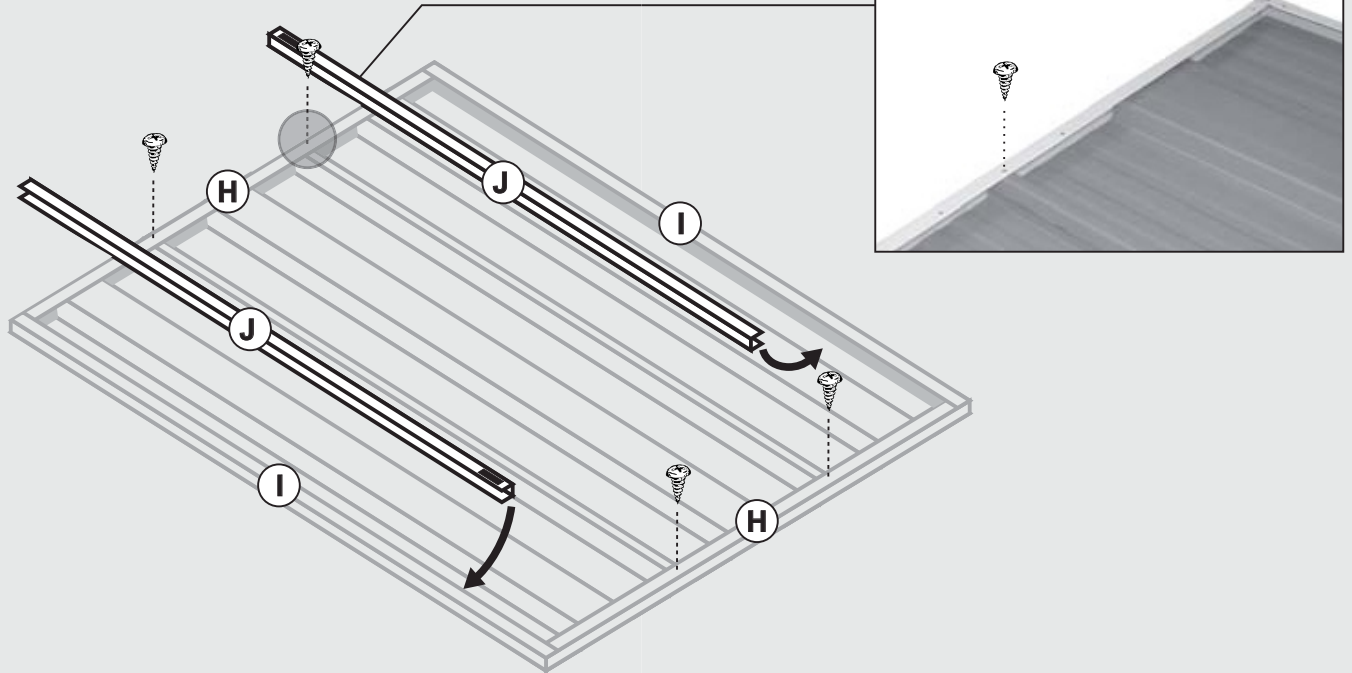

Fix the frame H to the sheeting with screws through the small channel lips into the large sheeting ribs. Door boxing must be fitted to the door frame.

3

Leave an even gap at both ends of the boxing.

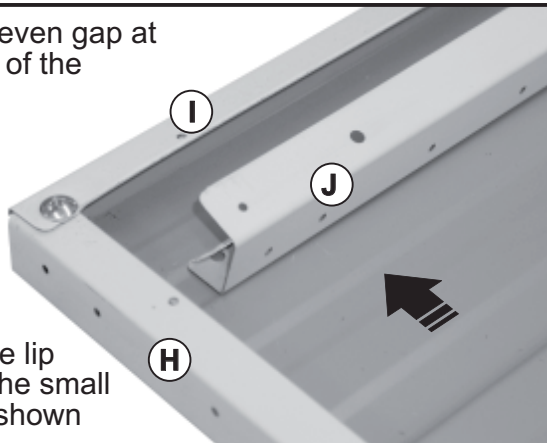

Place large lip of J over the small lip of I as shown

Screw the boxing to the frame as shown to the right

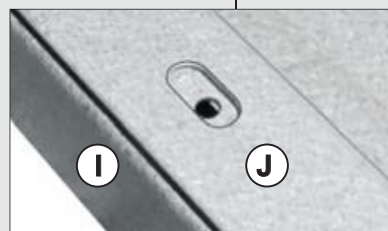
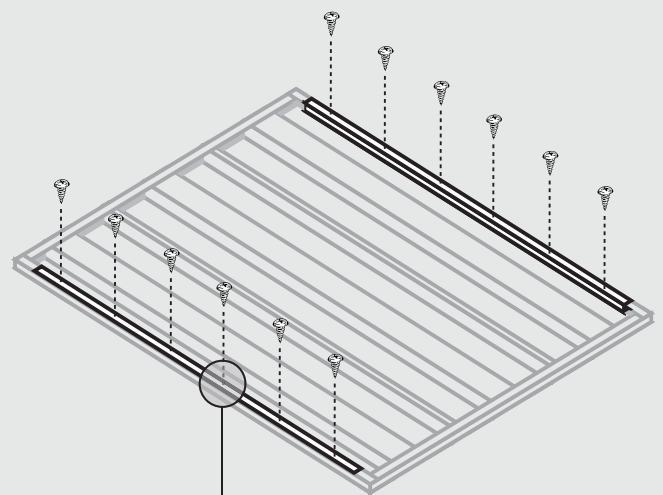
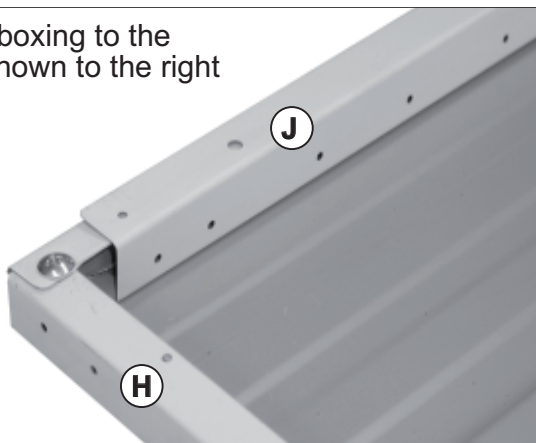

Fix both door boxing in place using six (6) screws.

ASSEMBLE DOOR

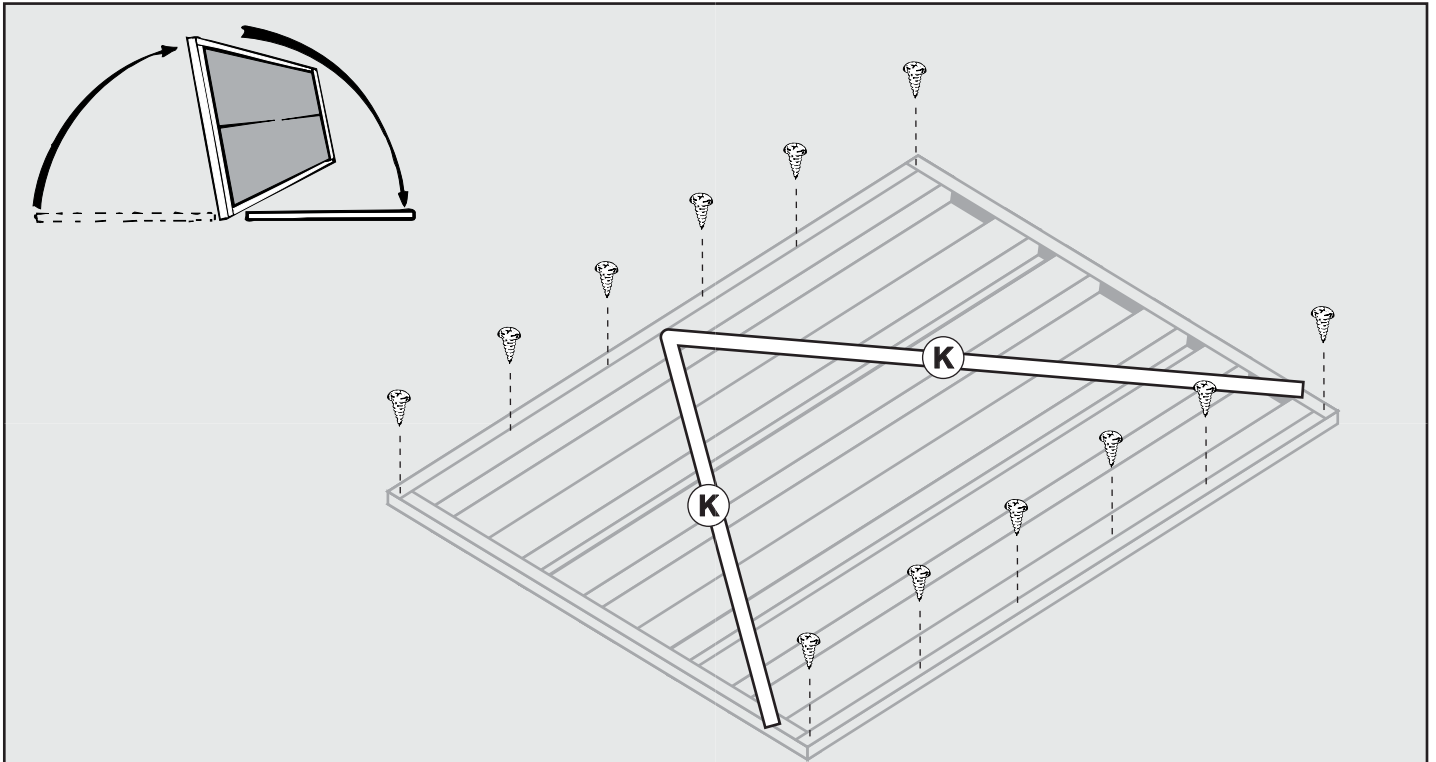

Flip the door assembly over and fix the door frame with screws evenly spaced as shown above. Door bracing will also need to be fitted to the door to ensure sturdiness.

4

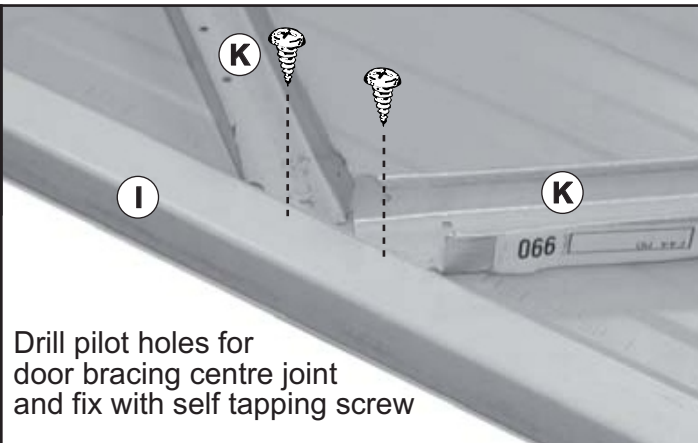

Drill pilot holes for door bracing centre joint and fix with self tapping screw

Drill pilot hole for top and bottom bracing joint, and fix with self tapping screw.

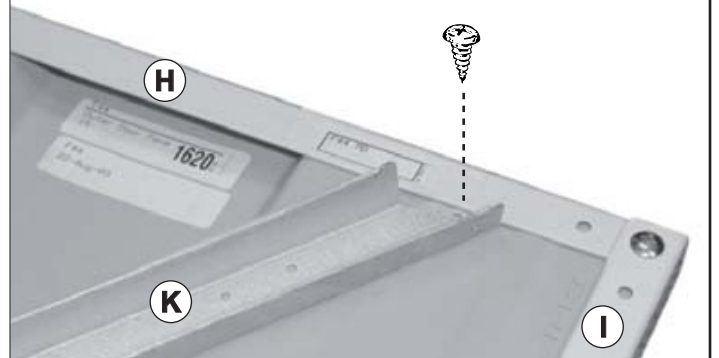

5

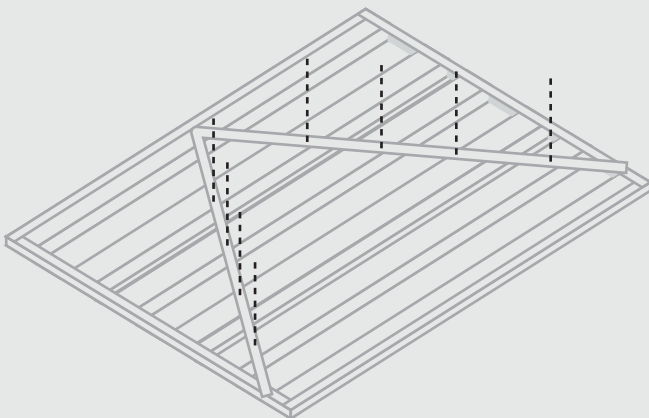

Use the 2.5mm drill bit to drill pilot holes through the door bracing into the door sheeting.

DO NOT FASTEN BRACING YET

ASSEMBLE DOOR

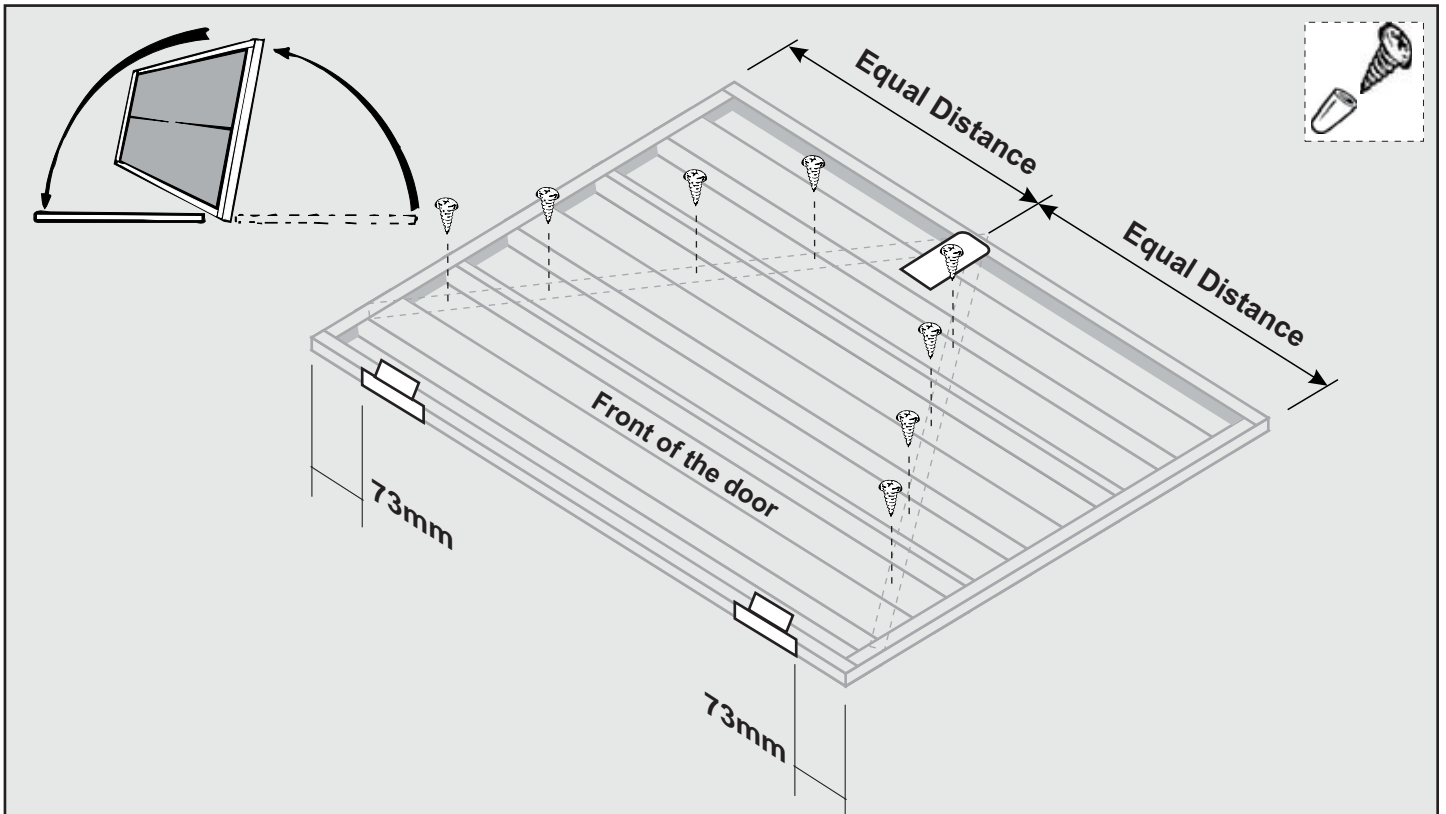

Flip the door back over to the front side facing up. Using the pilot holes drilled before, fix the door bracing from the front with self tapping screws.

6

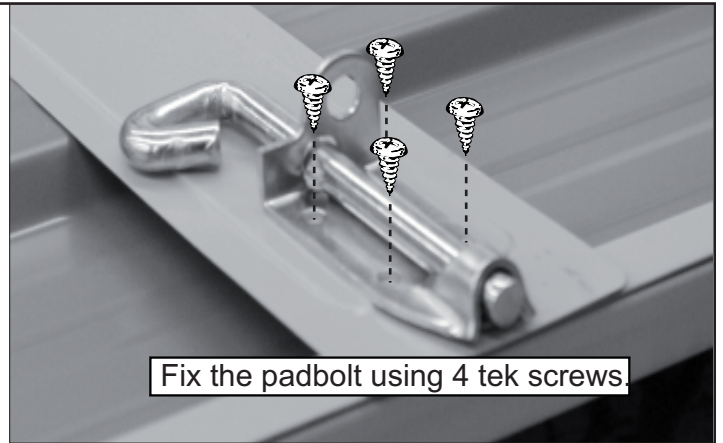
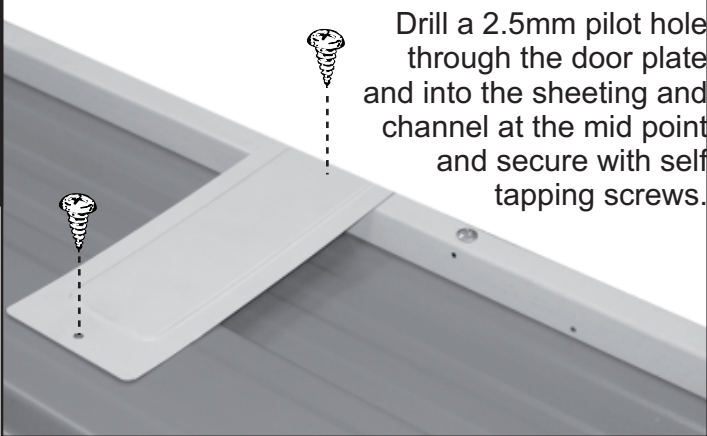

7

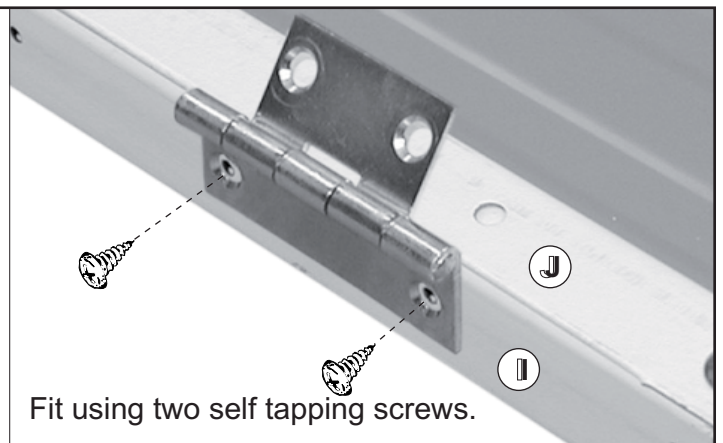
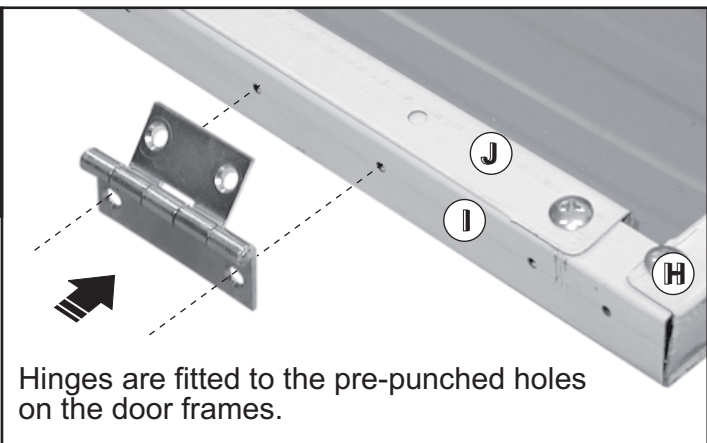

BOLT DOWN

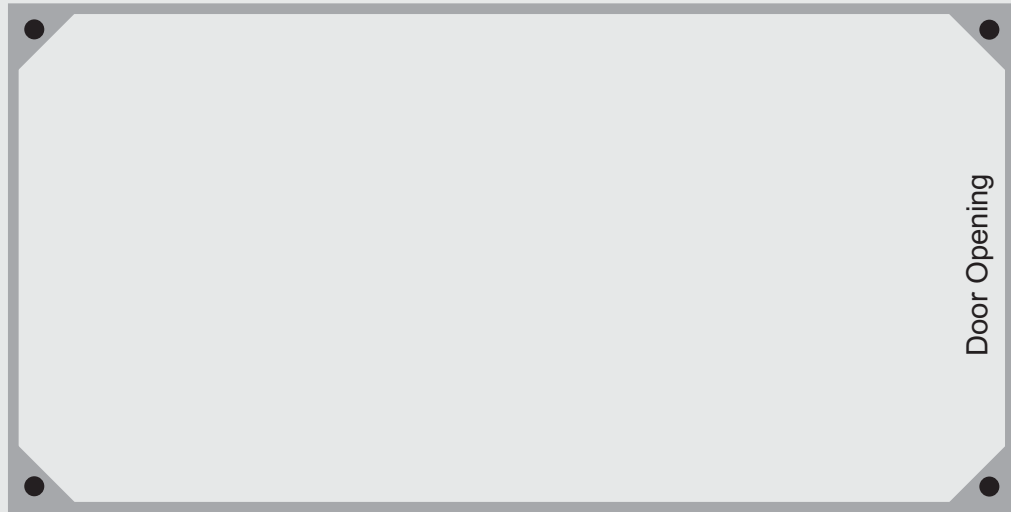

Bolt the shed down through the four corner brackets as shown. Ensure the shed is square.

1

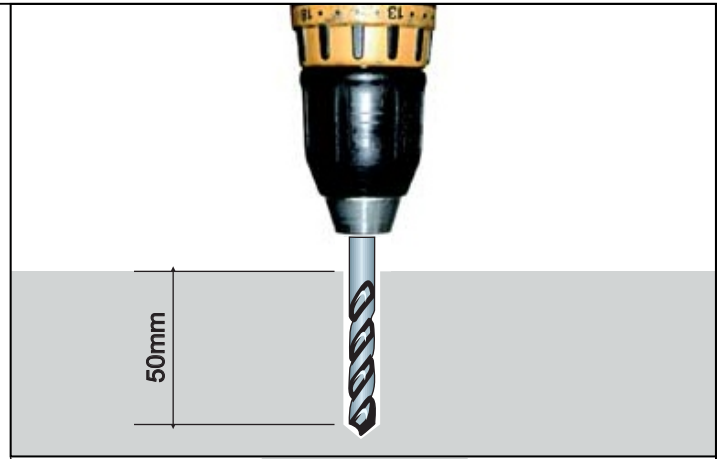
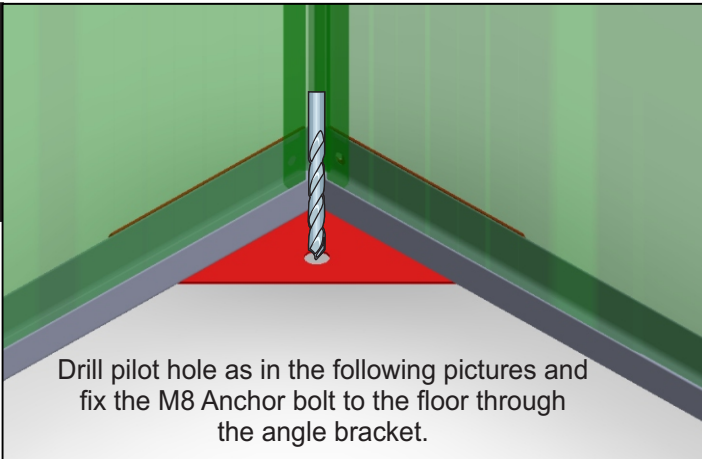

2

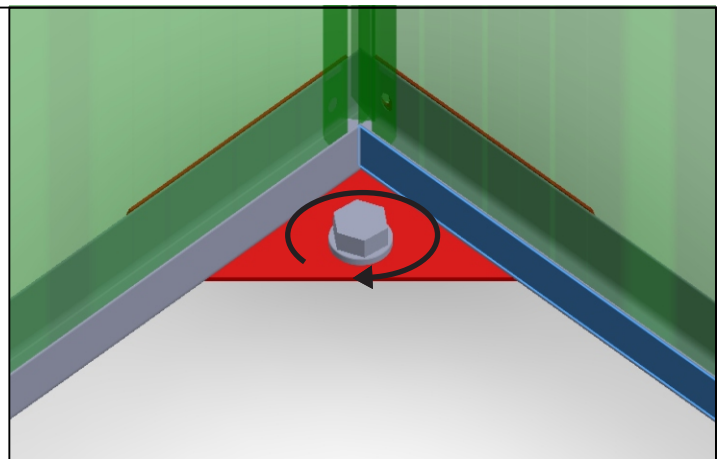
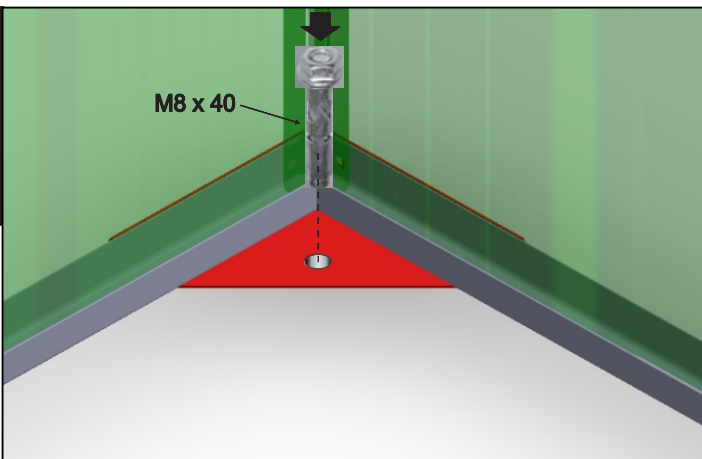

BOLT DOWN

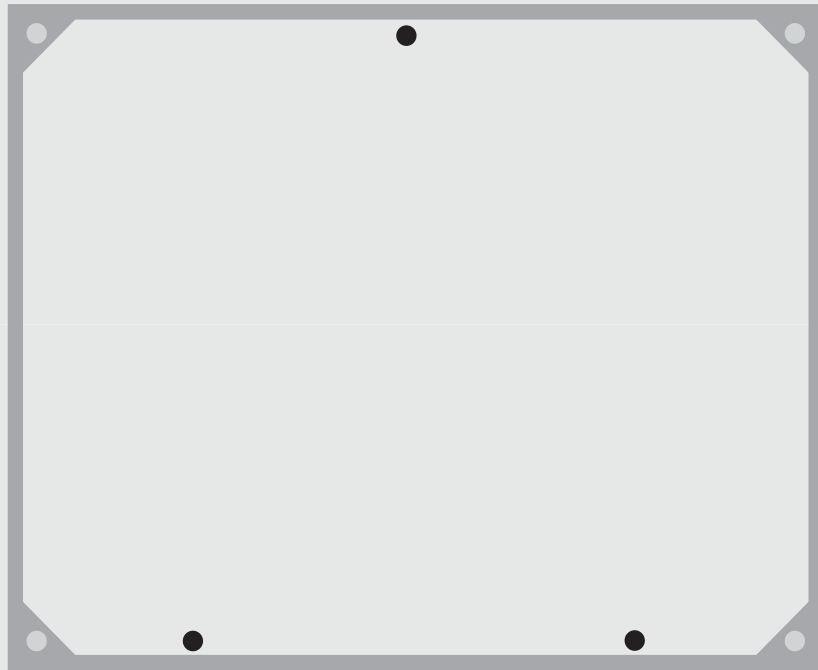

Bolt the shed down through the angle brackets as shown.

1

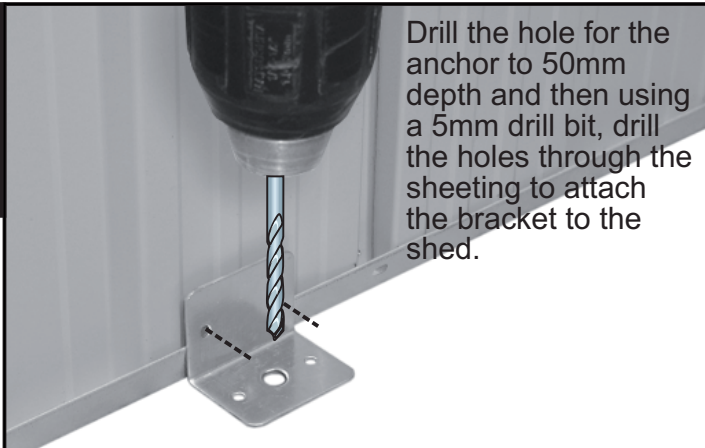

Drill the hole for the anchor to 50mm depth and then using a 5mm drill bit, drill the holes through the sheeting to attach the bracket to the shed.

50mm



2

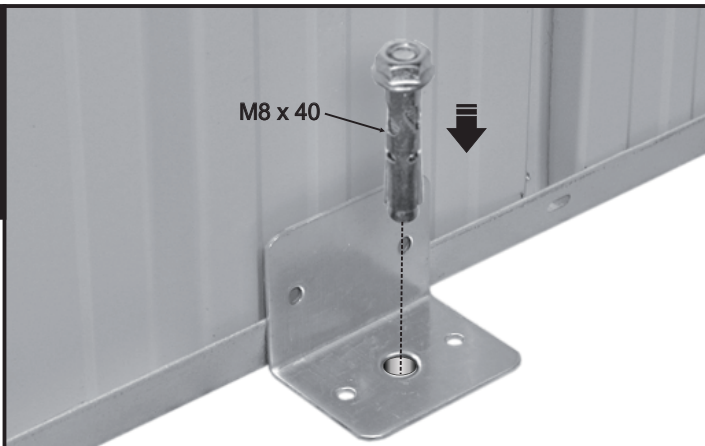

M8 x 40

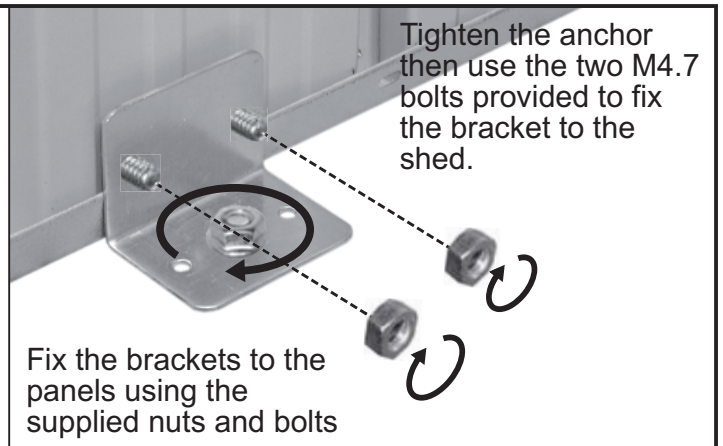

Tighten the anchor then use the two M4.7 bolts provided to fix the bracket to the shed.

Fix the brackets to the panels using the supplied nuts and bolts

HANG DOOR

NOTE: The diagram below shows a 44 flat roof shed. The assembly process is the same for all sheds.

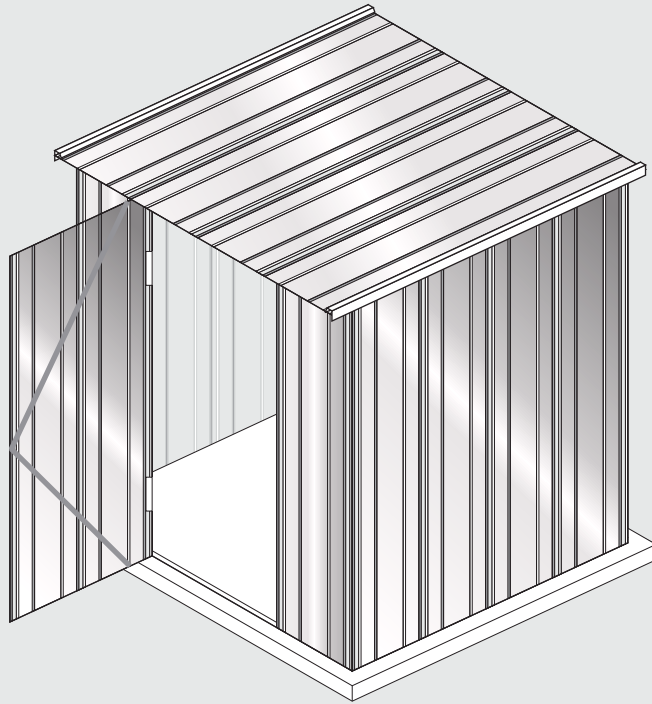

Fit the door to the left or right by fixing the hinges to the pre-drilled holes in the door jambs then fit the padbolt keeper.

1



2



Drill pilot holes to accommodate the padbolt keeper and then fix with self tapping screws



Simple, Strong,
Quick & Easy

15 Years Warranty

Thank you for purchasing FASTTRAK® system steel garden shed.

Your personal warranty is backed by Spanbilt, the manufacturer of FASTTRAK® system garden sheds, and our proven commitment to quality and customer service.

Our goods come with guarantees that cannot be excluded under Australian consumer law.

You are entitled to a replacement or refund of a major failure and Compensation for any reasonably foreseeable loss or damage. You are also entitled to have the goods repaired or replaced if the goods fail to be of acceptable quality and the failure does not amount to a major failure. Cost of claiming the warranty will be by the claimant.

This warranty is in addition to other rights and remedies of the customer under law.

Eligibility

- The 15 year warranty is eligible only to the original purchaser/owner of the shed as registered within 60 days from the date of purchase and is not transferrable.
- The warranty is valid for both Australia & New Zealand
- The warranty is subject to location and local environmental conditions outlined in the warranty exclusions below.

What is covered under the warranty?

FASTTRAK® steel garden shed 15 year warranty is limited to the following specific cover.

1. Zinc and/or galvanised panel materials will not rust
2. Coloured panel materials will not rust, flake, peel or blister.

Please note the 15 year warranty does not apply to any accessory items such as fasteners, Hasp, Pad bolts, also including flooring kits, shelving, hook sets, tool racks etc.

Warranty Qualifications & Limitations

The FASTTRAK® 15 year warranty is subject to the following qualifications and limitations

1. Warranty does not apply to surface deterioration of the panels caused specifically by
 - a. "Swarf"(tiny particles of steel debris left from cutting, grinding or drilling operations) that have not been dutifully removed during the assembly construction process.
 - b. As a result of contact with damp soil, chemicals, fertilisers, or other corrosive substances
2. Warranty does not cover damage caused by storms, wind, rain, hail, snow or any other adverse environmental event or "act of god"
3. Warranty only applies if the shed is used solely for domestic purposes and installation is in accordance and compliance with the FASTTRAK® instruction manual and manufacturer recommendations.
4. Warranty does not apply if the shed is installed / located in
 - a. Ocean/surf locations (typically defined as within 1km from coastal or tidal locations),
 - b. Severe industrial locations
 - c. Unusually corrosive environments (e.g. Geothermal / Sulphuric conditions)
5. Warranty does not cover any damage as a result of
 - a. Any impact
 - b. Due to poor foundations
 - c. Modifications
 - d. Build-up of debris on or in roof or walls
 - e. Poor assembly and/or construction
6. The warranty will be void if the shed has been relocated from its original location / address
7. The warranty is limited to the replacement and delivery of panels and specifically excludes any labour, installation or removal/disposal costs.
8. Warranty applies to the exclusions of all other representations, guarantees or warranties, either expressed or implied unless otherwise required by applicable legislation.
9. Your warranty registration certificate and supporting documentation must be completed and lodged within 60 days of the date of purchase.

Warranty Claims

All warranty claims should be made in writing sent directly to:

Australia

Spanbilt
PO Box 1581,
Browns Plains, Queensland, 4118

New Zealand

Spanbilt
PO Box 11-013,
Sockburn, Christchurch, 8443

Claims must include:

- a) Original proof of purchase documentation
- b) Relevant contact information
- c) Product model
- d) Photographic evidence
- e) Description of the damage



**Simple, Strong,
Quick & Easy.**

Warranty Registration Certificate

Owners Details

Owners Name:

Street Address:

City:

Postcode:

Email:

Building Details

Product Model Number:

Colour:

Place of Purchase:

Purchase Date:

Please attach here a photocopy of proof of purchase

Retain the original for your records

You must submit your warranty registration certificate within 60 days of the purchase date of your FASTTRAK® garden shed.

Post your certificate and supporting documentation to:

Australia

Spanbilt

PO Box 1581, Browns Plains

Queensland, 4118

New Zealand

Spanbilt

PO Box 11-013,

Sockburn, Christchurch 8443

FASTTRAK

**Simple, Strong,
Quick & Easy.**

**PO Box 1581
Browns Plains, QLD 4118**

**Enquiries
07 3827 8000
Fax
1800 222 166**

**Building Advice Line
1800 032 077
www.spanbilt.com.au**

**112 Waterloo Road
PO Box 11-013
Sockburn, Christchurch**

**TELEPHONE
03 349 3480
Fax
0800 772 6245
www.spanbilt.co.nz**

Another Quality Product From

